

*Tender Fee: Rs. 5,000/-
(Non-Refundable)*

TENDER FORM
TECHNICAL DOCUMENT
Tender # CW/30/25-26

**Providing, Installation, Testing, Commissioning of Fire
Hydrant System at IBA Main Campus Karachi**

Date of Issue : June 22, 2026

Last Date of Submission : July 08, 2026 (2:30 pm)

Date of Opening : June 08, 2026 (3:00pm)

Company Name: _____

NTN: _____

SRB / GST Registration Number: _____

Pay Order / Demand Draft # _____, Drawn on Bank _____

Amount of Rs. _____, Dated: _____

Contents

| | |
|--|------------------------------|
| INSTRUCTIONS TO BIDDERS | 7 |
| A. GENERAL | 7 |
| IB.1 Scope of Bid | 7 |
| IB.2 Source of Funds | 7 |
| IB.3 Eligible Bidders | 7 |
| IB.4 One Bid per Bidder | 7 |
| IB.5 Cost of Bidding | 7 |
| IB.6 Site Visit | 7 |
| B. BIDDING DOCUMENTS | 7 |
| IB.7 Contents of Bidding Documents | 7 |
| IB.8 Clarification of Bidding Documents | 8 |
| IB.9 Amendment of Bidding Documents | 8 |
| C. PREPARATION OF BIDS | 8 |
| IB.10 Language of Bid | 8 |
| IB.11 Documents Comprising the Bid | 8 |
| IB.12 Bid Prices | 9 |
| IB.13 Currencies of Bid and Payment | 9 |
| IB.14 Bid Validity | 9 |
| IB.15 Bid Security | 10 |
| IB.16 Alternate Proposal by Bidder | 10 |
| IB.17 Pre-Bid Meeting | 10 |
| IB.18 Format and Signing of Bid | 11 |
| D. SUBMISSION OF BIDS | 11 |
| IB.19 Sealing and Marking of Bids | 11 |
| IB.20 Deadline for Submission of Bids | 12 |
| IB.21 Late Bids | 12 |
| IB.22 Modification, Substitution and Withdrawal of Bids | 12 |
| E. BID OPENING AND EVALUATION FOR SINGLE STAGE | 13 |
| IB.23 Bid Opening | 13 |
| IB.24 Process to be Confidential | 13 |
| IB.25 Clarification of Bids | 13 |
| IB.26 Examination of Bids and Determination of Responsiveness | 14 |
| IB.27 Correction of Errors | 14 |
| IB.28 Evaluation and Comparison of Bids | 14 |
| F. AWARD OF CONTRACT | 14 |
| IB.29 Award | 14 |
| IB.30 The Employer's Right to Accept or Reject any or all Bids | 15 |
| IB.31 Notification of Award | 15 |
| IB.32 Performance Security | 15 |
| IB.33 Signing of Contract Agreement | 15 |
| IB.34 General Performance of the Bidders | 16 |
| IB.35 Integrity Pact | 16 |
| IB.36 Instructions not Part of Contract | 16 |
| BIDDING DATA | Error! Bookmark not defined. |

| | |
|---|-------------------------------------|
| 1. GENERAL PROVISIONS | 20 |
| The Contract | 20 |
| Persons | 20 |
| Dates, Times and Periods | 20 |
| Money and Payments | 21 |
| Other Definitions | 21 |
| 2. THE EMPLOYER..... | 22 |
| 3. EMPLOYER'S REPRESENTATIVES | 22 |
| 4. THE CONTRACTOR | 23 |
| 5. DESIGN BY CONTRACTOR | 23 |
| 6. EMPLOYER'S RISKS | 24 |
| 7. TIME FOR COMPLETION | 24 |
| 8. TAKING-OVER | 25 |
| 9. REMEDYING DEFECTS | 25 |
| 10. VARIATIONS AND CLAIMS | 26 |
| 11. CONTRACT PRICE AND PAYMENT TERMS | 27 |
| 12. DEFAULT | 27 |
| 13. RISKS AND RESPONSIBILITIES | 28 |
| 14. INSURANCE..... | 29 |
| 15. RESOLUTION OF DISPUTES | 29 |
| 16. INTEGRITY PACT | 30 |
| 17. PRIORITY OF CONTRACT DOCUMENTS:..... | 30 |
| CONTRACT DATA | 36 |
| LETTER OF TECHNICAL BID | 38 |
| LETTER OF PRICE BID | 39 |
| APPENDICES TO BID..... | 40 |
| PROPOSED CONSTRUCTION SCHEDULE | 41 |
| LIST OF SUBCONTRACTORS..... | 42 |
| PAST EXPERIENCE, PERSONNEL CAPABILITIES AND FINANCIAL | 43 |
| STRENGTH..... | 43 |
| Appendix-D to Bid | 44 |
| JOINT VENTURE AGREEMENT | 45 |
| INTEGRITY PACT..... | 46 |
| PROOF OF PURCHASE OF RFP | 47 |
| DECLARATION OF BENEFICIAL OWNERS | 48 |
| AFFIDAVIT OF BLACKLISTING..... | 51 |
| SPECIFIC SYSTEM DATA CHECKLIST | Error! Bookmark not defined. |
| BILL OF QUANTITIES | Error! Bookmark not defined. |
| SPECIFICATIONS | 64 |
| FORM OF BID SECURITY | 86 |
| FORM OF PERFORMANCE SECURITY..... | 93 |
| FORM OF ADVANCE PAYMENT..... | 95 |
| FORM OF CONTRACT AGREEMENT | 99 |
| LIST OF APPROVED MANUFACTURERS | |

INVITATION FOR BIDS

Notice Invitation Tender

The Institute of Business Administration, Karachi (IBA) invites sealed bids from active taxpayers of manufacture and authorized distributor registered with relevant tax and other energy regulatory authorities for the following tender. The Equipment offered by the Bidder must be according to NFPA-20 specification; alternate proposal will not be acceptable.

| Tender Title (Ref. No.) | Procedure | Bid Security |
|--|---------------------------|--------------|
| Providing, Installation , Testing, Commissioning of Fire Hydrant System at IBA Main Campus Karachi (CW/30/25-26) | Single Stage Two Envelope | 2% |
| <ul style="list-style-type: none">• Fee: Rs.5,000/-• Issuance start date: June 22, 2026 at 9 AM• Issuance end date & time: July 08, 2026 at 2:30 PM• Submission date & time: June 22, 2026 to July 08, 2026 from 9 AM to 2:30 PM• Opening date & time: July 08, 2026 at 3:00 PM• Site Visit: July 03, 2026, at 11 AM at IBA Main Campus | | |

Tender Document containing detailed terms and conditions are available at Office of **Head of Procurement, Fauji Foundation Building, IBA Main Campus, University Enclave, Karachi** on any working day (Monday to Friday). The tender document can also be downloaded from IBA and SPPRA EPADS system. The Tender fee challan is to be generated from the IBA website <https://www.iba.edu.pk/tenders/> which may be deposited in any branch of Meezan Bank Ltd. Bidders are required to submit their bids (duly signed and stamped) on the uploaded Tender Document (along with a copy of Earnest Money and all supporting documents) through SPPRA EPADS system (www.eprocure.gov.pk). The original bid security along with the Original Bid (duly signed and stamped) must be delivered to IBA, Karachi on below mentioned address before bid opening and will be opened on same date & venue in the presence of the bidders' representatives who may wish to attend. Bid Security in the form of Pay Order or Demand Draft has to be submitted in favour of "**IBA Karachi**".

N.B.

(1) IBA Karachi reserves the right to reject any bid or cancel the bidding process subject to relevant provision of SPP Rules 2010.

(2) Only uploaded bid along with supporting documents will be accepted. In case there is a contradiction between bidder's EPADS submitted bid and manually submitted bid, bid submitted on EPADS will be considered valid for evaluation purpose.

REGISTRAR

IBA, Main Campus, Univeristy Enclave, Karachi 75270

111-422-422 Fax (92-21) 99261508

Contact Person Assistant Manager Procurement on 38104700 ext: 2150

Email tenders@iba.edu.pk

Website <https://www.iba.edu.pk/tenders/>

SPPRA EPADS: <https://portalsindh.eprocure.gov.pk/#/>

INSTRUCTIONS TO BIDDERS

INSTRUCTIONS TO BIDDERS

(Note: These Instructions to Bidders along with Bidding Data will not be part of the Contract and will cease to have effect once the contract is signed.)

A. GENERAL

IB.1 Scope of Bid

- 1.1 The **Employer** (as defined in the Bidding Data) wishes to receive bids for the Design, Supply, Installation, Testing & Commissioning of Fire Hydrant System as described in these Bidding Documents, and summarized in the Bidding Data hereinafter referred to as the **"Works"**.
- 1.2 The Successful Bidder will be expected to complete the Works within the time specified in Appendix-A to the Bid.

IB.2 Source of Funds

- 2.1 The Employer has available to it sufficient resources / funds to completely finance the Supply, Installation, construction, Testing, Commissioning and completion of the Works.

IB.3 Eligible Bidders

- 3.1 This Invitation for Bids is open to all bidders registered with active tax Payer List of FBR & PEC Category C-6 and above with relevant Specialization code ME-02

IB.4 One Bid per Bidder

- 4.1 Each bidder shall submit only one bid either by himself, or as a partner in a Joint Venture. A bidder who submits or participates in more than one bid (other than alternatives pursuant to Clause IB.16) will be disqualified.

IB.5 Cost of Bidding

- 5.1 The bidders shall bear all costs associated with the preparation and submission of their respective bids and the Employer will in no case be responsible or liable for those costs, regardless of the conduct or outcome of the bidding process.

IB.6 Site Visit

- 6.1 The bidders may visit and examine the Site of Works and its surroundings and obtain for themselves on their own responsibility all information that may be necessary for preparing the bid and entering into a contract for the Works. All cost in this respect shall be at the bidder's own expense.
- 6.2 The bidders and any of their personnel or agents will be granted permission by the Employer to enter upon its premises and lands for the purpose of such inspection, but only upon the express condition that the bidders, their personnel and agents, will release and indemnify the Employer, his personnel and agents from and against all liability in respect thereof and will be responsible for death or personal injury, loss of or damage to property and any other loss, damage, costs and expenses incurred as a result of such inspection.

B. BIDDING DOCUMENTS

IB.7 Contents of Bidding Documents

- 7.1 The Bidding Documents, in addition to invitation for bids, are those stated below and should be read in conjunction with any Addenda issued in accordance with Clause IB.9.
1. Instructions to Bidders;
 2. Bidding Data;
 3. Letters of Technical Bid & Price Bid;
 4. Appendices to Bid;
 5. Conditions of Contract;
 6. Contract Data;
 7. Form of Bid Security;
 8. Form of Performance Security;
 9. Form of Advance Payment Guarantee;
 10. Form of Contract Agreement;
 11. Specifications & Employer Design.
- 7.2 The bidders are expected to examine carefully the contents of all the above Bidding Documents. Failure to comply with the requirements of bid submission will be at the Bidder's own risk. Pursuant to Clause IB.26, bids which are not substantially responsive to the requirements of the Bidding Documents will be rejected.

IB.8 Clarification of Bidding Documents

- 8.1 Any prospective bidder requiring any clarification(s) in respect of the Bidding Documents may notify the Employer in writing at the Employer's address indicated in the Invitation for Bids. **The Employer will respond to any request for clarification which he receives at least five (5) days prior to the deadline for submission of bids.**
- 8.2 Copies of the Employer's response will be forwarded to all purchasers of the Bidding Documents, including a description of the enquiry but without identifying its source.

IB.9 Amendment of Bidding Documents

- 9.1 At any time prior to the deadline for submission of bids, the Employer may, for any reason, whether at his own initiative or in response to a clarification requested by a prospective bidder, modify the Bidding Documents by issuing addendum.
- 9.2 Any addendum thus issued shall be part of the Bidding Documents pursuant to Sub-Clause 7.1 hereof and shall be communicated in writing to all purchasers of the Bidding Documents. Prospective bidders shall acknowledge receipt of each addendum in writing to the Employer.
- 9.3 To afford prospective bidders reasonable time in which to take an addendum into account in preparing their bids, the Employer may extend the deadline for submission of bids in accordance with Clause IB.20

C. PREPARATION OF BIDS

IB.10 Language of Bid

- 10.1 The bid and all correspondence and documents related to the bid exchanged by a bidder and the Employer shall be in the bid language stipulated in the Bidding Data and particular Conditions of Contract. Supporting documents and printed literature furnished by the bidders may be in any other language provided the same are accompanied by an accurate translation of the relevant parts in the bid language, in which case, for purposes of evaluation of the bid, the translation in bid language shall prevail.

IB.11 Documents Comprising the Bid

- 11.1 **The Bid shall comprise two envelopes submitted simultaneously, one called the Technical Bid and the other Price Bid, containing the documents listed in Bidding Data under the heading of 11.1 A & B respectively. Both envelopes to be enclosed together in an outer single envelope called the Bid. Each bidder shall furnish all the documents as specified in Bidding Data at 11.1 A & B.**

- 11.2 Bids submitted by a Joint Venture (JV) shall include a copy of the JV Agreement entered into by all partners. Alternatively, a letter of intent to execute a JV Agreement in the event of a successful bid shall be signed by all partners and submitted with the bid, together with a copy of the proposed agreement. The role to be played by each partner to be specified therein. Bids submitted by a JV of two (2) or more firms shall comply with the following requirements:
- (a) In case of successful bid, the form of JV Agreement shall be signed and be registered as per law so as to be legally binding on all partners **within four (4) days of the receipt of Letter of Acceptance** failing which the contract and the Letter of Acceptance shall stand void and redundant.
 - (b) **One of the JV partners shall be nominated as being in charge who must be registered with PPIB under AEDB (Certification) Regulations 2021** and this Authorization shall be evidenced by submitting a power of attorney signed by legally authorized signatories of all the JV partners. In case of a company submitting chain of Authority including board resolution to this effect or any authorization required under the law shall be mandatory.
 - (c) The partners-in-charge shall always be duly authorized to deal with the Employer regarding all matters related with and/or incidental to the execution of Works as per the terms and conditions of JV Agreement and in this regard to incur any and all liabilities, receive instructions, give binding undertakings and receive payments on behalf of the JV.
 - (d) All partners of the JV shall at all times and under all circumstances be liable jointly and severally for the execution of the Contract in accordance with the Contract terms and a statement to this effect shall be included in the authorization mentioned under Sub-Para (b) above as well as in the Form of Bid and in the Form of JV Agreement (in case of a successful bid): and
 - (e) A copy of JV Agreement shall be submitted before signing of the Contract, stating the conditions under which JV will function, its period of duration, the persons authorized to represent and obligate it and which persons will be directly responsible for due performance of the Contract and can give valid receipts on behalf of the JV, and any other information necessary to permit a full appraisal of its functioning. The JV agreement shall be deemed part of the Contract. No amendments/modifications whatsoever in the JV agreement shall be agreed to between the JV partners without prior written consent of the Employer.

11.3 The Bidder shall furnish, as part of the Technical Bid, a Technical Proposal including a statement of work methods, equipment, personnel, schedule and any other information as stipulated in the Bidding Forms, in sufficient detail to demonstrate the adequacy of Bidders' proposal to meet the Works requirements and the completion time referred to in sub-clause 1.2 hereof.

IB.12 Bid Prices

- 12.1 Unless stated otherwise in the Bidding Documents, the Contract shall be for the whole of the Works as described in Sub-Clause 1.1 hereof, based on lump sum price of the Works. **The criteria for evaluation of bids are provided in the Bidding Data.**
- 12.2 All duties, taxes and other levies payable by the Contractor under the Contract, or for any other cause shall be included in the rates and prices and the total Bid Price submitted by a bidder. After the date of bid submission deadline, any additional / reduced duties, taxes and levies due to subsequent additions or changes in legislation shall be reimbursed / deducted.

IB.13 Currencies of Bid and Payment

13.1 The price of the Works shall be quoted by the bidders entirely in Pak rupees.

IB.14 Bid Validity

14.1 Bids shall remain valid for the period stipulated in the Bidding Data after the Date of Bid Opening specified in Clause IB.23.

- 14.2 In exceptional circumstances, prior to expiry of the original bid validity period, the Employer may request that the bidders extend the period of validity for a specified additional period which shall in no case be more than the original bid validity period. The request and the responses thereto shall be made in writing. A bidder may refuse the request without forfeiting his Bid Security. A bidder agreeing to the request will not be required or permitted to modify his bid, but will be required to extend the validity of his Bid Security for the period of the extension, and in compliance with Clause IB.15 in all respects.

IB.15 Bid Security

- 15.1 Bidders to furnish a fixed amount of 2% Bid security of the estimated value mentioned in APP vide SPP Rule 37 in the form of Deposit at Call/ Payee's Order or a Bank Guarantee issued by a Scheduled Bank in Pakistan in favor of the Procuring Agency
- 15.2 The Bid Security shall be, at the option of the bidder, in the form of Demand Draft, Call Deposit Receipt, Pay Order or a Bank Guarantee issued by a Scheduled Bank in Pakistan in favour of and acceptable to the Employer valid for a period Forty five (45) days beyond the Bid Validity date.
- 15.3 Any bid not accompanied by an acceptable Bid Security shall be rejected by the Employer as non-responsive.
- 15.4 The bid securities of unsuccessful bidders will be returned as promptly as possible, but not later than fifteen (15) days after the expiration of the period of Bid Validity.
- 15.5 The Bid Security of the Successful Bidder will be returned when the bidder has furnished the required Performance Security and signed the Contract.
- 15.6 The Bid Security may be forfeited:
- (a) If the bidder withdraws his bid except as provided in Sub-Clause 22.1;
 - (b) If the bidder does not accept the correction of his Bid Price pursuant to Sub-Clause 27.2 hereof; or
 - (c) In case of Successful Bidder, if he fails within the specified time limit to:
 - (i) Furnish the required Performance Security; or
 - (ii) Sign the Contract.
 - (iii) Furnish the required JV agreement within four (4) Days of the receipt of Letter of Acceptance.

IB.16 Alternate Proposal by Bidder

- 16.1 Should any bidder consider that he can offer any advantages to the Employer by a modification to the specifications or other conditions, he may, in addition to his bid to be submitted in strict compliance with the Bidding Documents, submit any Alternate Proposal(s) containing
- (a) relevant design specifications/calculations;
 - (b) technical specifications;
 - (c) proposed construction methodology; and
 - (d) any other relevant details / conditions, provided always that the total sum entered on the Form of Bid shall be that which represents complete compliance with the Bidding Documents. The technical details and financial implications involved are to be submitted in two separate sealed envelopes as to be followed in main bid proposals.
- 16.2 Alternate Proposal(s), if any, of the lowest evaluated responsive bidder in sole discretion of the Employer may only be considered by the Employer as the basis for the award of Contract to such bidder.

IB.17 Pre-Bid Meeting

- 17.1 The Employer may, on his own motion/discretion or at the request of any prospective bidder(s), hold a pre-bid meeting to clarify issues and to answer any questions on matters related to the Bidding Documents. The date, time and venue of pre-bid meeting is as stipulated in the Bidding Data. All prospective bidders or their authorized representatives shall be invited to attend such a pre bid meeting.
- 17.2 The bidders are requested to submit questions, if any, in writing so as to reach the Employer not later than three (3) days before the proposed pre-bid meeting.
- 17.3 Minutes of the pre-bid meeting, including the text of the questions raised and the replies given, will be transmitted without delay to all purchasers of the Bidding Documents. Any modification of the Bidding Documents listed in Sub Clause 7.1 hereof which may become necessary as a result of the pre-bid meeting shall be made by the Employer exclusively through the issue of an Addendum pursuant to Clause IB.9 and not through the minutes of the pre-bid meeting.
- 17.4 Absence at the pre-bid meeting will not be a cause for disqualification of a bidder.

IB.18 Format and Signing of Bid

- 18.1 Bidders are particularly directed that the amount entered on the Form of Bid shall be for performing the Contract strictly in accordance with the Bidding Documents.
- 18.2 All appendices to Bid are to be properly completed and signed.
- 18.3 **No alteration is to be made in the Form of Bid nor in the Appendices thereto except in filling up the blanks as directed. If any such alterations be made or if these instructions be not fully complied with, the bid may be rejected.**
- 18.4 Each bidder shall prepare by filling out the forms completely and without alterations one (1) original and one (1) copy of the documents comprising the bid and clearly mark them "ORIGINAL" and "COPY" as appropriate. In the event of discrepancy between them, the original shall prevail.
- 18.5 The original and the copy of the bid shall be typed or written in indelible ink (in the case of copies, Photostats are also acceptable) and shall be signed by a person or persons duly authorized to sign on behalf of the bidder. This authorization shall consist of a written confirmation as specified in the Bidding Data and shall be attached to the bid. The name and position held by each person signing the authorization must be typed or printed below the signature. All pages of the Bid, except for un-amended printed literature, shall be signed or initiated by the person signing the bid.
- 18.6 The bid shall contain no alterations, omissions or additions, except to comply with instructions issued by the Employer, or as are necessary to correct errors made by the bidder, in which case such corrections shall be initialed by the person or persons signing the bid.
- 18.7 Bidders shall indicate in the space provided in the Form of Bid their full and proper addresses at which notices may be legally served on them and to which all correspondence in connection with their bids and the Contract is to be sent.
- 18.8 Bidders should retain a copy of the Bidding Documents as their file copy.

D. SUBMISSION OF BIDS

IB.19 Sealing and Marking of Bids

- 19.1 Each bidder shall submit his bid as under:

- (a) ORIGINAL and the copy of the Bid shall be separately sealed and put in separate envelopes and marked as such.
- (b) The envelopes containing the ORIGINAL and copy will be put in one sealed envelope and addressed / identified as given in Sub- Clause 19.2 hereof.
- (c) **The technical bid should comprise of documents listed in 11.1 (A) of Bidding Data & the Price Bid should comprise of documents listed in 11.1 (B) of Bidding Data which shall be placed in separate envelopes in accordance with 11.1.**

19.2 The inner and outer envelopes shall:

- (a) Be addressed to the Employer at the address provided in the Bidding Data;
- (b) Bear the name and identification number of the tender as defined in the Bidding Data; and
- (c) Provide a warning not to open before the time and date for bid opening, as specified in the Bidding Data.

19.3 In addition to the identification required in Sub- Clause 19.2 hereof, the inner envelope shall indicate the name and address of the bidder to enable the bid to be returned unopened in case it is declared "late" pursuant to Clause IB.21.

19.4 If the outer envelope is not sealed and marked as above, the Employer will assume no responsibility for the misplacement or premature opening of the Bid.

IB.20 Deadline for Submission of Bids

- 20.1 (a) Bids must be received by the Employer at the address specified no later than the time and date stipulated in the Bidding Data or such extended deadline as the Employer has duly notified in accordance with Clause IB.9.
- (b) Bids with charges payable will not be accepted, nor will arrangements be undertaken to collect the bids from any delivery point other than that specified above. Bidders shall bear all expenses incurred in the preparation and delivery of bids. No claims will be entertained for refund of such expenses. (c) Where delivery of a bid is by mail and the bidder wishes to receive an acknowledgment of receipt of such bid, he shall make a request for such acknowledgment in a separate letter attached to but not included in the sealed bid package.
- (d) Upon request, acknowledgment of receipt of bids will be provided to those making delivery in person or by messenger.
- 20.2 The Employer may, at his discretion, extend the deadline for submission of bids by issuing an amendment in accordance with Clause IB.9, in which case all rights and obligations of the Employer and the bidders previously subject to the original deadline will thereafter be subject to the deadline as extended.

IB.21 Late Bids

- 21.1 (a) **Any bid received by the Employer after the deadline for submission of bids prescribed in Clause IB.20 will be returned unopened to such bidder.**
- (b) Delays in the mail, delays of person in transit, or delivery of a bid to the wrong office shall not be accepted as an excuse for failure to deliver a bid at the proper place and time. It shall be the bidder's responsibility to determine the manner in which timely delivery of his bid will be accomplished either in person, by messenger or by mail.

IB.22 Modification, Substitution and Withdrawal of Bids

22.1 Any bidder may modify, substitute or withdraw his bid after bid submission provided that the modification, substitution or written notice of withdrawal is received by the Employer prior to the deadline for submission of bids.

- 22.2 The modification, substitution, or notice for withdrawal of any bid shall be prepared, sealed, marked and delivered in accordance with the provisions of Clause IB.19 with the outer and inner envelopes additionally marked "MODIFICATION", "SUBSTITUTION" or "WITHDRAWAL" as appropriate.
- 22.3 No bid may be modified by a bidder after the deadline for submission of bids except in accordance with Sub-Clauses 22.1 and 27.2.
- 22.4 Withdrawal of a bid during the interval between the deadline for submission of bids and the expiration of the period of bid validity specified in the Form of Bid may result in forfeiture of the Bid Security in pursuance to Clause IB.15.

E. BID OPENING AND EVALUATION FOR SINGLE STAGE TWO ENVELOPE BIDDING PROCEDURE

IB.23 Bid Opening

- 23.1 The Employer will open the Technical Bids in public at the address, date and time specified in the Bidding Data in the presence of Bidders' designated representatives and anyone who choose to attend. The Price Bid will remain unopened and will be held in custody of the Employer until the specified time of their opening.
- 23.2 First, envelopes marked "WITHDRAWALS" shall be opened and read out and the envelope with the corresponding bid shall not be opened, but returned to the Bidder. No bid withdrawals shall be permitted unless the corresponding withdrawal Notice contains a valid authorization to request the withdrawal and is read out at bid opening.
- 23.3 Second, outer envelopes marked "SUBSTITUTION" shall be opened. The inner envelopes containing the substitution Technical Bid and/or Substitution Price Bid shall be exchanged for the corresponding envelopes being substituted, which are to be returned to the Bidder unopened. Only the Substitution Technical Bid, if any, shall be opened, read out, and recorded. Substitution Price Bid will remain unopened in accordance with IB 23.1. No envelope shall be substituted unless the corresponding.
- 23.4 Next, outer envelopes marked "MODIFICATION" shall be opened. No Technical Bid and /or Price Bid shall be modified unless the corresponding Modification Notice contains a valid authorization to request the modification and is read out and recorded at the opening of Technical Bids. Only the Technical Bids, both Original as well as Modification, are to be opened, readout, and recorded in accordance with IB 23.1. The Bidders' representatives who are present shall be requested to sign the record. The omission of a Bidders signature on the record shall not invalidate the contents and effect of the record. A copy of the record shall be distributed to all Bidders.

IB.24 Process to be Confidential

Information relating to the examination, clarification, evaluation and comparison of bid and recommendations for the award of a contract shall not be disclosed to bidders or any other person not officially concerned with such process before the announcement of bid evaluation report which shall be done at least seven (07) days prior to issue of Letter of Acceptance. The announcement to all Bidders will include table(s) comprising read out prices, discounted prices, price adjustments made, final evaluated prices and recommendations against all the bids evaluated. Any effort by a bidder to influence the Employer's processing of bids or award decisions may result in the rejection of such bidder's bid. However, any bidder feeling aggrieved may lodge a written complaint concerning his grievances within seven (07) days of announcement of technical evaluation report and five (05) days after issuance of final evaluation report; however mere fact of lodging a complaint shall not warrant suspension of the procurement process

IB.25 Clarification of Bids

25.1 To assist in the examination, evaluation and comparison of bids, the Employer may, at his discretion, ask any bidder for clarification of his bid. The request for clarification and the response shall be in writing but no change in the price or substance of the bid shall be sought, offered or permitted except as required to confirm the correction of arithmetic errors discovered by the Employer in the evaluation of the bids in accordance with Clause IB.28.

25.2 If a bidder does not provide clarifications of its Bid by the date and time set in the Employer's request for clarification, its bid may be rejected.

IB.26 Examination of Bids and Determination of Responsiveness

26.1 Prior to the detailed evaluation of bids, the Employer will determine whether each bid is substantially responsive to the requirements of the Bidding Documents.

26.2 A substantially responsive bid is one which (i) meets the eligibility and qualification criteria under the Bidding Documents; (ii) has been properly signed; (iii) is accompanied by the required Bid Security; and (iv) conforms to all the terms, conditions and specifications of the Bidding Documents, without material deviation or reservation. A material deviation or reservation is one (i) which affect in any substantial way the scope, quality or performance of the Works; (ii) which limits in any substantial way, inconsistent with the Bidding Documents, the Employer's rights or the bidder's obligations under the Contract; or (iii) adoption/rectification whereof would affect unfairly the competitive position of other bidders presenting substantially responsive bids. Only substantially responsive bids shall be considered for further evaluation.

26.3 If a bid is not substantially responsive, it will be rejected by the Employer, and may not subsequently be made responsive by correction or withdrawal of the non-conforming deviation or reservation. The Employer may, however, seek confirmation / clarification in writing which shall be responded in writing.

IB.27 Correction of Errors

27.1 Bids determined to be substantially responsive will be checked by the Employer for any arithmetic errors and where there is a discrepancy between the amounts in figures and in words, the amount in words will govern.

27.2 The amount stated in the Form of Bid will be adjusted by the Employer in accordance with the above procedure for the correction of errors and with the concurrence of the bidder, shall be considered as binding upon the bidder. If the bidder does not accept the corrected Bid Price, his Bid will be rejected, and the Bid Security shall be forfeited in accordance with Sub- Clause 15.6(b) hereof.

IB.28 Evaluation and Comparison of Bids

28.1 The Employer will evaluate and compare only those Bids which are substantially responsive in accordance with Clause IB.26.

28.2 In evaluating the Bids, the Employer will determine for each Bid the evaluated Bid Price by adjusting the Bid Price for errors pursuant to Clause IB.27.

28.3 The estimated effect of the price adjustment provisions of the Conditions of Contract due to Variation, applied over the period of execution of the Contract, shall not be taken into account in Bid evaluation.

F. AWARD OF CONTRACT

IB.29 Award

- 29.1 Subject to Clauses IB.30 and IB.34, the Employer will award the Contract to the bidder whose bid has been determined by the Employer to be substantially responsive to the Bidding Documents and who has offered the lowest evaluated Bid Price, provided that such bidder has been determined to be eligible in accordance with the provisions of Clause IB.3 and qualify pursuant to criteria provided in the Bidding Documents.
- 29.2 The Employer, at any stage of the bid evaluation, having credible reasons for or *prima facie* evidence of any defect in supplier's or contractor's capacities, may require the suppliers or contractors to provide information concerning their professional, technical, financial, legal or managerial competence whether already pre-qualified or not:

Provided that such qualification shall only be laid down after recording reasons therefor in writing. They shall form part of the records of that bid evaluation report.

IB.30 The Employer's Right to Accept any Bid and to Reject any or all Bids

- 30.1 Notwithstanding anything contained herein, the Employer reserves the right to accept or reject any Bid, and to annul the bidding process and reject all bids, at any time prior to award of Contract, without thereby incurring any liability to the affected bidders or any obligation except that the grounds for rejection of all bids shall upon request be communicated to any bidder who submitted a bid, without justification of grounds. Rejection of all bids shall be notified to all bidders promptly.

IB.31 Notification of Award

31.1 Prior to expiration of the period of bid validity prescribed by the Employer, the Employer will notify the successful bidder in writing ("Letter of Acceptance") that his Bid has been accepted. This letter shall name the sum which the Employer will pay the Contractor in consideration of the execution and completion of the Works by the Contractor as prescribed by the Contract Agreement (hereinafter and in the Conditions of Contract called the "Contract Price").

31.2 No Negotiation with the bidder having evaluated as lowest responsive or any other bidder shall be permitted.

31.3 The notification of award and its acceptance by the bidder will constitute the formation of the contract, binding the Employer and the bidder till signing of the formal Contract.

31.3 Upon furnishing by the successful bidder of a Performance Security, the Employer will promptly notify the other bidders that their Bids have been unsuccessful and return their bid securities.

IB.32 Performance Security

32.1 The successful bidder shall furnish to the Employer a Performance Security in the form and the amount stipulated in the Bidding Data and the Conditions of Contract within a period of seven (7) working days after the receipt of Letter of Acceptance.

32.2 Failure of the successful bidder to comply with the requirements of Sub-Clause IB.32.1 or Clauses IB.33 or IB.35 shall constitute sufficient grounds for the annulment of the award and forfeiture of the Bid Security.

IB.33 Signing of Contract Agreement

33.1 Simultaneously with the furnishing of acceptable Performance Security under the Conditions of Contract, the formal Contract Agreement between the Employer and the Successful Bidder (s) shall be executed.

IB.34 General Performance of the Bidders

The Employer reserves the right to obtain information regarding performance of the bidders on their previously awarded contracts/works. The Employer may in case of consistent poor performance of any Bidder as reported by the employers of the previously awarded contracts, inter alia, reject his bid and/or take such action as may be deemed appropriate under the circumstances of the case including black listing of such Bidder.

IB.35 Integrity Pact

The Bidder shall sign and stamp the Integrity Pact provided at Appendix E to Bid in the Bidding Documents for all Government procurement contracts exceeding Rupees ten million. Failure to provide such Integrity Pact shall make the bidder non-responsive.

IB.36 Instructions not Part of Contract

Bids shall be prepared and submitted in accordance with these Instructions which are provided to assist bidders in preparing their bids, and do not constitute part of the Bid or the Contract Documents.

IB.37 Sufficiency of Bid

Each Bidder shall be deemed to have satisfied fully, before submitting the Bid, as to all aspects of the Works, correctness and sufficiency of his Bid and price stated in the Price Bid which price shall, except in so far as it is otherwise expressly provided in the Contract Agreement, cover all his obligations under the Contract Agreement and all matters and things necessary for the proper completion of Works. Objections, excuses or claims made by the bidder after submission of his Bid to the Employer shall not be entertained.

IB.38 Sub-Contractors

Any Sub-Contractor is subject to the acceptance of the Employer and the Sub-Contract shall be subject to the same Conditions of Contract as the main Contract. A list, as set forth in Appendix "B" showing the name and address and credentials of each proposed sub-Contractor, the type of work to be sub-let and the reason for subletting shall be submitted with the Bid. Overall responsibility of all Works, whether parts of it subcontracted or not, shall rest with the Bidder.

IB.39 Taxes & Duties

The Bidder shall obtain all information as to Pakistan Income Tax, Sales Tax, Salaries Tax, Professional Tax, Company Tax, Municipal Octroi, Levies and any other taxes imposed by the local bodies, export and import duties, import surcharge, etc. and necessary permits and confirm the requirements thereof at his own responsibility and include all such cost in his Bid price. The quoted rate shall also include the cost of accepting the general risks/liabilities and obligations set forth or implied in the Contract.

IB.40 Insurance

The Bidder shall estimate the amounts required to be provided for all the insurances under the Contract from National Insurance Company Limited (NICL), Pakistan in accordance with the laws applicable in Pakistan and the Bid Price shall be deemed to include all such amounts.

IB.41 Indexation

The Bidder shall prepare and submit the Bid Price of the Works taking into account the TT & OD selling rate of US Dollar as notified by the State Bank of Pakistan /National Bank of Pakistan (NBP) as of date which is five (05) days

prior to bid submission deadline.

IB.42 Foreign Exchange Availability for LCs Opening

The foreign exchange required by the Successful Bidder for import of equipment/opening of the LCs will be arranged by the bidder himself.

BIDDING DATA

The information in this section is complementary to, amends or supplements the provisions in the Instructions to Bidders. Whenever there is conflict, the provisions herein shall take precedence over those in the Instructions to Bidders.

| Reference to instruction to Bidder | Bidding Data |
|---|--|
| IB-I 1.1 | Name of the Project & Summary of the Works “Supply, Installation, Testing & Commissioning of Fire Hydrant System at IBA Main Campus Karachi University Enclave Karachi [Name of Procuring Agency/Employer]. INSTITUTE OF BUSINESS ADMINISTRATION (IBA) KARACHI The Works shall be performed/executed as per the Specifications provided in the Bidding Documents and approved Contractor Design as per the Conditions of Contract”. |
| 1.1 | Name and Address of Employer Institute of Business Administration (IBA) Karachi IBA Main Campus University of Karachi Enclave Karachi UAN 111-422- 422 www.iba.edu.pk |
| IB-10 10.1 | <u>Bid Language:</u> English |

| | |
|---|--|
| <p>IB-11 11.1</p> | <p><u>11.1 (A)</u> The Bidder shall submit with its documents required for fulfilling mandatory/eligibility criteria and technical evaluation criteria. The following documents: (a) Letter of Technical Bid (b) Bid Security (IB.15) (c) Authorizing the signatory of the Bid (IB.18.5) (d) Proposed Construction Schedule (e) List of Sub-Contractors (f) Past Performance and Financial Strength (g) Joint Venture Agreement (if applicable) (h) Integrity Pact (i) Proof of purchase of RFP (j) Declaration of Beneficial Ownership</p> <p><u>11.1 (B)</u> The Bidder shall submit with its Price Bid the following documents: (a) Letter of Price Bid (b) Bill of Quantities (BOQ) (Appendix-K)</p> |
| <p>IB-12</p> | <p><u>Merit Point Evaluation</u> The items ranked highest in merit points (obtained through and based on technical and financial evaluation) will get unit rate Contract.</p> |
| <p>IB-14 14.1</p> | <p><u>Bid Validity</u> Period of Bid Validity shall be ninety (90) days from the date of Bid Opening.</p> |
| <p>IB-15 15.1</p> | <p><u>Bid Security</u> Bidders to furnish a fixed amount of 2% Bid security of the estimated value mentioned in APP vide SPPRA Rule 37 in the form of Deposit at Call/ Payee's Order or a Bank Guarantee issued by a Scheduled Bank in Pakistan in favor of the Procuring Agency</p> |
| <p>IB-17 17.1</p> | <p><u>Site Visit</u> The Site visit meeting will be held on July 03, 2026 at 11am at IBA Main Campus Karachi.</p> |
| <p>IB-19 19.2 (a)</p> | <p><u>Address for the purpose of Bid submission:</u> Hard Copy will be submitted on Gate No 4 IBA Main Campus Karachi University Enclave.</p> |
| <p>IB-20 20.1</p> | <p><u>Deadline for submission of Bids:</u> At or before 3:00 PM on or before June 03, 2026 (or otherwise as notified in the letter of invitation for Bids).</p> |
| <p>IB-32 32.1</p> | <p><u>Performance Security:</u> 5% of the bid Price in the form of an irrevocable & unconditional bank guarantee from any Scheduled Bank of Pakistan acceptable to the Employer as per Form of Performance Security provided in the Bidding Documents or Pay order of the Prescribed amount by a Schedule Bank of Pakistan issued in favour of the Employer i.e IBA Karachi..</p> |

| | |
|--|---|
| | <p><u>Payment</u></p> <ol style="list-style-type: none"> 1. <u>Mobilization Advance</u> : 10 % of the bid quoted by the vender shall be paid as mobilization against bank guarantee from a schedule bank in favour of IBA as per form attached. 2. <u>Secured Advance</u> : 75 % of the material cost as per rate quoted in BOQ delivered at site as per contract specification and verified by the Engineer Incharge shall be paid upon submission of Indenture Bond as enclosed in Bidding documents . 3. <u>Retention</u> : 10 % Retention amount shall be deducted from each payment as retention amount. 50 % of this retention amount shall be release upon successful completion of the commissioning of the project along with payment of final bill and the balance 50 % of the retention amount shall be paid upon successful completion of the Liquidated damages period and issuance of discharge certificate. |
| | <p><u>Project Completion Time</u> : 180 (One hundred eighty working days) from the signing of the contract agreement.</p> |
| | <p><u>Liquidity Damages</u> : 0.05 % of the bidding cost for each day or maximum 10 % of the bidding cost which ever is lesser if the work is not executed with in stipulated completion time/ extended time (if it is extended by the competent authority.</p> |
| | <p><u>Safety Protocol</u> : The vendor shall follow the safety protocol of IBA.</p> |

CONDITIONS OF CONTRACT

1. GENERAL PROVISIONS

1.1 Definitions

In the Contract as defined below, the words and expressions defined shall have the following meanings assigned to them, except where the context requires otherwise:

The Contract

- 1.1.1 “Contract” means the Contract Agreement and the other documents listed therein.
- 1.1.2 “Specifications” means the minimum specifications of the equipment being parts of the net-metering based Fire Hydrant System as set out in the Bidding Documents and any Variation to such document.
- 1.1.3(A) “Employer Design” means the design of the Fire Hydrant System as set out in the Bidding Documents and any Variation to such design.
- 1.1.3(B) “Contractor Design” means the design of the Fire Hydrant System, prepared and submitted by the Contractor to the Employer under this Contract, based on the specifications of the offered equipment which design shall be in conformity with the Employer Design.

Persons

- 1.1.4 “Employer” means the person named in the Contract Data and the legal successors in title to this person, but not (except with the consent of the Contractor) any assignee.
- 1.1.5 “Contractor” means the person named in the Contract Data whose Bid has been accepted by the Employer and the legal successors in title to such person, but not (except with the consent of the Employer) any assignee of such person.”
- 1.1.6 “Party” means either the Employer or the Contractor.

Dates, Times and Periods

- 1.1.7 “Commencement Date” means the date as mentioned in the Contract Data.
- 1.1.8 “Day” means a calendar day.
- 1.1.9 “Time for Completion” means the time for completion of the Works as stated in the Contract Data (or as extended under Sub-Clause 7.3), calculated from the Commencement Date.

Money and Payments

- 1.1.10 “Cost” means all expenditure properly incurred (or to be incurred) by the Contractor, whether on or off the Site, including overheads and similar charges but does not include any allowance for profit.

Other Definitions

- 1.1.11 “Contractor’s Equipment” means all machinery, apparatus and other things required for the execution of the Works but does not include Materials or System intended to form part of the Works.
- 1.1.12 “Country” means the Islamic Republic of Pakistan.
- 1.1.13 “Employer’s Risks” means those matters listed in Sub-Clause 6.1.
- 1.1.14 “Force Majeure” means an event or situation beyond the control of a Party that is not foreseeable, is unavoidable and its origin is not due to negligence or lack of care on the part of such Party. Such events subject to the conditions as stated in the preceding sentence may include, but not be limited to, wars or revolutions, fires, floods, epidemics, quarantine restrictions, and freight embargoes.
- 1.1.15 “Materials” means things of all kinds (other than System) to be supplied and incorporated in the Works by the Contractor.
- 1.1.16 “System” means the machinery and apparatus intended to form or forming part of the Works.
- 1.1.17 “Site” means the place mentioned in the Contract Data where the Works are to be executed, and any other place(s) specified in the Contract as forming part of the Site.
- 1.1.18 “Variation” means a change which is instructed by the Employer under SubClause 10.1.
- 1.1.19 “Works” means any or all the works including design, supply, installation, construction, testing and commissioning of the System to be performed by the Contractor including temporary works and any Variation thereof.
- 1.1.20 “Engineer” means a qualified engineer/engineering firm appointed by the Employer to act as independent engineer for the purpose of the Contract for review of the Contractor Design, equipment inspection and verification of installed System.
- 1.1.21 “Letter of Acceptance” means the formal acceptance by the Employer of the Tender.
- 1.1.22 “Tender” means the Contractor's priced offer to the Employer for the execution and completion of the Works and the remedying of any defects therein in accordance with the provisions of the Contract, as accepted by the Letter of Acceptance.

1.2 Interpretation

Words importing persons or parties shall include firms and organizations. Words importing singular or one gender shall include plural or the other gender where the context requires.

1.3 Priority of Documents

The documents forming the Contract are to be taken as mutually explanatory of one another. If an ambiguity or discrepancy is found in the documents, the priority of the documents shall be in accordance with the order as listed in the General Provisions of the Conditions of Contract.

1.4 Law

The rights and obligations of the Parties under the Contract shall be governed by laws of the Islamic Republic of Pakistan.

1.5 Communications

All Communications related to the Contract shall be in English language.

1.6 Statutory Obligations

The Contractor shall comply with the laws of the Islamic Republic of Pakistan and shall give all notices and pay all fees and other charges in respect of the Works.

2. THE EMPLOYER

2.1 Provision of Site

The Employer shall provide the Site and right of access thereto at the times stated in the Contract Data.

2.2 Permits etc.

The Contractor shall be exclusively responsible to apply for and obtain from Govt agency if so applicable. The Employer shall, if requested by the Contractor, assist him in applying for permits, licenses or approvals which are required for the Works.

2.3 Employer's Instructions

The Contractor shall comply with all instructions given by the Employer, in respect of the Works including the suspension of all or part of the Works.

2.4 Approvals

No approval or consent or absence of comment by the Employer shall affect the Contractor's obligations required under the Contract.

3. EMPLOYER'S REPRESENTATIVES

The Employer shall appoint with precise scope of authority and notify in writing a duly authorized person to act for him and on his behalf for the purposes of this Contract. The details and precise scope of the authority of such authorized person shall be notified in writing to the Contractor immediately after the signing of the Contract.

4. THE CONTRACTOR

4.1 General Obligations

The Contractor shall carry out the Works as per the highest standards of workmanship and in accordance with the terms and conditions of the Contract. The Contractor shall provide all supervision, labour, materials, plant and Contractor's equipment which may be required for the execution of the Works and shall also arrange all permits and licenses at his own cost, required for installation, commissioning and operation of the System.

4.2 Contractor's Representative

The Contractor shall appoint a representative at site on full time basis to supervise the execution of Works and to receive instructions on behalf of the Contractor but only after obtaining the consent of the Employer for such appointment which consent shall not be unreasonably withheld by the Employer. Such authorized representative may be substituted/replaced by the Contractor at any time during the Contract Period but only after obtaining the consent of the Employer as aforesaid.

4.3 Subcontracting

The Contractor shall not subcontract the whole of the Works. The Contractor may subcontract any part of the Works subject to restriction stipulated in the Contract Data.

4.4 Performance Security

The Contractor shall furnish to the Employer within seven (07) working days after receipt of Letter of Acceptance a Performance Security, in the form of irrevocable & unconditional Bank Guarantee or Pay order from any Scheduled Bank of Pakistan acceptable to the Employer for the amount and validity specified in Contract Data.

5. DESIGN BY CONTRACTOR

5.1 Submission and Approval of Contractor Design

The Contractor shall promptly submit the work plan and shop drawing or Contractor Design to the Employer for approval. Within seven (7) days of receipt, the Employer shall notify any comments or, if the design submitted is not in accordance with the Contract, shall reject it stating the reasons. The Contractor shall not construct any element of the Works designed by him within seven (7) days after the design has been submitted to the Employer or which has been rejected. Design that has been rejected shall be promptly amended and resubmitted.

5.2 Responsibility for Design

Notwithstanding that the Contractor Design is submitted and approved by the Employer, the Contractor shall solely remain responsible for his rendered design under this Contract, which shall not only be in strict conformity with the Employer Design and Specifications but also be fit for the intended purposes defined in the Contract. In addition, the Contractor shall also be solely responsible for any infringement of any patent or copyright in respect of such design.

6. EMPLOYER'S RISKS

6.1 The Employer's Risks

The Employer's Risks are: -

- a) politically motivated riot, commotion or disorder by persons other than the Contractor's personnel and other employees including the personnel and employees of Sub-Contractors, directly affecting the Site and/or the Works;
- b) use or occupation by the Employer of any part of the Works, except as may be specified in the Contract;
- c) late handing over of Site;
- d) a suspension under Sub-Clause 2.3 unless it is attributable to the Contractor's failure; and
- e) physical obstructions or physical conditions other than climatic conditions, encountered on the Site during the performance of the Works, for which the Contractor immediately notified to the Employer and accepted by the Employer.

6.2 Loss or Damage due to Employer's Risks

In the event of any such loss or damage happening from any of the risks defined in Sub-Clause 6.1 or force majeure, or in combination with other risks, the Contractor shall, if and to the extent required by the Employer, rectify the loss or damage and the Employer shall determine an addition to the Contract Price in accordance with Clause 10 and shall notify the Contractor accordingly. In the case of a combination of risks causing loss or damage any such determination shall take into account the proportional responsibility of the Contractor and the Employer.

7. TIME FOR COMPLETION

7.1 Execution of the Works

The Contractor shall commence the Works on the Commencement Date and shall proceed expeditiously and without delay and shall complete the Works, subject to Sub-Clause 7.3 below, within the Time for Completion as stated in the Contract Data.

7.2 Programme

Within the time stated in the Contract Data, the Contractor shall submit to the Employer a detailed programme for the Works incorporating the dates,

which programme shall be in-line with the Proposed Construction Schedule submitted along with the Bid.

7.3 **Extension of Time**

The Contractor shall, within such time as may be reasonable under the circumstances, notify the Employer of any event(s) falling within the scope of Sub-Clause 6.1 or 10.3 of these Conditions of Contract and request the Employer for a reasonable extension in the time for the completion of Works. Subject to the aforesaid, the Employer shall determine such reasonable extension in the time for the completion of Works as may be justified in the light of the details/particulars supplied by the Contractor in connection with the such determination by the Employer within such period as may be prescribed by the Employer for the same; and the Employer shall extend the Time for Completion as determined.

7.4 **Late Completion**

If the Contractor fails to complete the Works within the Time for Completion, the Contractor's only liability to the Employer for such failure shall be to pay the amount stated in the Contract Data for each day for which he fails to complete the Works.

8. **TAKING-OVER**

8.1 **Notice of Completion by the Contractor**

The Contractor shall notify in writing to the Employer when he considers that the Works are complete in all aspects.

8.2 **Taking-Over Notice**

Within ten (10) days of receipt of notice of completion from the Contractor, the Engineer shall determine the conformity of the installed System with the approved Contractor Design and notify the Contractor through Employer that the Works are complete in accordance with the Contract. The Employer shall take over the Works upon the issue of this notice and issue Taking Over Certificate to the Contractor.

Alternatively, the Contractor shall be notified that the Works are not ready for taking over, stating the reasons accordingly. The Contractor shall then promptly complete any outstanding work and, subject to Clause 9, clear the site.

8.3 **Defect Liability Period**

Defect Liability Period shall be as stated in the Contract Data.

9. **REMEDYING DEFECTS**

9.1 **Remedying Defects**

The Employer may at any time prior to the expiry of the period stated in the Contract Data, notify the Contractor of any defects. The Contractor shall remedy at no cost to the Employer any defects due to the Contractor Design, Materials, System or workmanship not in accordance with the Contract.

The Cost of remedying defects attributable to any other cause shall be valued as a Variation. Failure to remedy any such defects or complete outstanding work within a reasonable time shall entitle the Employer to carry out all necessary works at the Contractor's cost.

9.2 **Uncovering and Testing**

The Employer may give instruction as to the uncovering and/or testing of any work. Unless as a result of an uncovering and/or testing it is established that the Contractor Design, Materials, System or workmanship are in accordance with the Contract, the Contractor shall be paid for such uncovering and/or testing as a Variation in accordance with Sub-Clause 10.2.

9.3 The Contractor at his own responsibility shall arrange all hoisting and fixing equipment necessary for the satisfactory completion of work and shall make good any damage to the existing surface.

10. VARIATIONS AND CLAIMS

10.1 **Right to Vary**

The Employer may instruct Variations.

10.2 **Valuation of Variations**

Variations shall be valued at a lump sum price mutually agreed between the Parties.

10.3 **Early Warning**

The Contractor shall notify the Employer in writing as soon as he is aware of any circumstance which may delay or disrupt the Works, or which may give rise to a claim for additional payment.

To the extent of the Contractor's failure to notify, which results to the Employer being unable to keep all relevant records or not taking steps to minimize any delay, disruption, or Cost, or the value of any Variation, the Contractor's entitlement to extension of the Time for Completion or additional payment shall be reduced/rejected.

10.4. **Valuation of Claims**

If the Contractor incurs Cost as a result of any of the Employer's Risks, the Contractor shall be entitled to the amount of such Cost. If as a result of any Employer's Risk, it is necessary to change the Works, this shall be dealt with as a Variation subject to Contractor's notification for intention of claim to the Employer within fourteen (14) days of the occurrence of cause.

10.5 **Variation and Claim Procedure**

The Contractor shall submit to the Employer an itemized make-up of the value of Variations and claims within twenty-one (21) days of the instruction or of the event giving rise to the claim. The Employer shall check and if possible agree the value. In the absence of agreement on the claim, the Employer shall determine the value.

11. CONTRACT PRICE AND PAYMENT TERMS

11.1 Contract Price

The Contract price shall be as provided in the Contract Data.

11.2 Payment Terms and Statements

Subject to the terms and conditions of the Contract, the Contractor shall be entitled to be paid the Contract Price at such intervals as given in the Contract Data.

12. DEFAULT

12.1 Default by Contractor

If the Contractor abandons the Works, refuses or fails to comply with a valid instruction of the Employer or fails to proceed expeditiously and without delay, or is, despite a written complaint,

in breach of the Contract, the Employer may give notice referring to this Sub-Clause and stating the default.

If the Contractor has not taken all practicable steps to remedy the default within seven (07) days after receipt of the Employer's notice, the Employer may by a second notice given within a further fourteen (14) days, terminate the Contract. The Contractor shall then immediately demobilize from the Site leaving behind any and all Contractor's Equipment which the Employer instructs, in the second notice, to be used for the completion of the Works at the risk and cost of the Contractor.

12.2 Default by Employer

If the Employer fails to pay in accordance with the Contract, or is, despite a written complaint, in breach of the Contract, the Contractor may give notice referring to this Sub-Clause and stating the default. If the default is not remedied within fourteen (14) days after the Employer's receipt of this notice, the Contractor may suspend the execution of all or parts of the Works.

12.3 Insolvency

If a Party is declared insolvent under any applicable law, the other Party may by notice terminate the Contract which shall be effective fourteen (14) days after receipt of notice by the other party. The Contractor shall then immediately demobilize from the Site leaving behind, in the case of the

Contractor's insolvency, any Contractor's Equipment which the Employer instructs in the notice is to be used for the completion of the Works.

12.4 **Payment upon Termination**

After termination, the Contractor shall be entitled to payment of the unpaid balance of the value of the Works executed and of the Materials and System reasonably delivered to the Site, adjusted by the following:

- a) any sums to which the Contractor is entitled under Sub-Clause 10.4,
- b) any sums to which the Employer is entitled,
- c) if the Employer has terminated under Sub-Clause 12.1 or 12.3, the Employer shall be entitled to a sum equivalent to twenty percent (20%) of the value of parts of the Works not executed at the date of the termination, and
- d) if the Contractor has terminated under Sub-Clause 12.2 or 12.3, the Contractor shall be entitled to the cost of his demobilization together with a sum equivalent to ten percent (10%) of the value of parts of the Works executed at the date of termination.

The net balance due shall be paid or repaid within twenty-eight (28) days of the notice of termination.

13. **RISKS AND RESPONSIBILITIES**

13.1 **Contractor's Care of the Works**

The Contractor shall take full responsibility for the care of the Works from the Commencement Date until the date of the Employer's issuance of Certificate of Completion under Sub-Clause 8.2. Responsibility shall then pass to the Employer. If any loss or damage happens to the Works during the above period, the Contractor shall rectify such loss or damage so that the Works conform with the Contract.

Unless the loss or damage happens as a result of any of the Employer's Risks, the Contractor shall indemnify the Employer, or his agents against all claims loss, damage and expense arising out of the Works.

13.2 **Force Majeure**

If Force Majeure occurs, the Contractor shall notify the Employer immediately. If necessary, the Contractor may suspend the execution of the Works and, to the extent agreed with the Employer demobilize the Contractor's Equipment.

If the event continues for a period of eighty-four (84) days, either Party may then give notice of termination which shall take effect twenty-eight (28) days after the giving of the notice.

After termination, the Contractor shall be entitled to payment of the unpaid balance of the value of the Works executed and of the Materials and System reasonably delivered to the Site, adjusted by the following:

- a) any sums to which the Contractor is entitled under Sub-Clause 10.4,
- b) the cost of his demobilization, and
- c) less any sums to which the Employer is entitled.

The net balance due shall be paid or repaid within thirty-five (35) days of the notice of termination.

14. INSURANCE

At all times during the execution of the Works, the Contractor shall maintain property insurance on the System for the replacement cost thereof, except for items (a) to (e) of the Employer's Risks.

15. RESOLUTION OF DISPUTES

15.1 Employer's Decision

If a dispute of any kind whatsoever arises between the Employer and the Contractor in connection with the Works, the matter in dispute shall, in the first place, be referred in writing to the Employer. Such reference shall state that it is made pursuant to this Clause. No later than the twenty-eight (28) days after the day on which he received such reference, the Employer shall give notice of his decision to the Contractor.

Unless the Contract has already been repudiated or terminated, the Contractor shall, in every case, continue to proceed with the Works with all due diligence, and the Contractor shall give effect forthwith to every such decision of the Employer unless and until the same shall be revised, as hereinafter provided in an arbitral award.

15.2 Notice of Dissatisfaction

If the Contractor is dissatisfied with the decision of the Employer or if no decision is given within the time set out in Sub-Clause 15.1 here above, the Contractor may give notice of dissatisfaction referring to this Sub-Clause within fourteen (14) days of receipt of the decision or the expiry of the time for the decision. If no notice of dissatisfaction is given within the specified time, the decision shall be final and binding on the Contractor. If notice of dissatisfaction is given within the specified time, the decision shall be binding on the Contractor who shall give effect to it without delay unless and until the decision of the Employer is revised by an arbitrator.

15.3 Arbitration

A dispute which has been the subject of a notice of dissatisfaction shall be finally settled as per provisions of Arbitration Act 1940 (Act No. X of 1940) and Rules made thereunder and any statutory modifications thereto. Any

hearing shall be held at the place specified in the Contract Data and in the language referred to in Sub-Clause 1.5.

16 INTEGRITY PACT

16.1 If the Contractor, or any of his Sub-Contractors, agents or servants is found to have violated or involved in violation of the Integrity Pact signed by the Contractor as Appendix-E to his Bid, then the Employer shall be entitled to:

- (a) recover from the Contractor an amount equivalent to ten times the sum of any commission, gratification, bribe, finder's fee or kickback given by the Contractor or any of his Sub-Contractors, agents or servants; (b) terminate the Contract; and
- (c) recover from the Contractor any loss or damage to the Employer as a result of such termination or of any other corrupt business practices of the Contractor or any of his Sub-Contractors, agents or servants.

On termination of the Contract under Sub-Para (b) of this Sub-Clause, the Contractor shall immediately demobilize from the Site leaving behind Contractor's Equipment which the Employer instructs, in the termination notice, to be used for the completion of the Works at the risk and cost of the Contractor. Payment upon such termination shall be made under Sub-Clause 12.4, in accordance with Sub-Para (c) thereof, after having deducted the amounts due to the Employer under Sub-Para (a) and (c) of this Sub-Clause.

17. PRIORITY OF CONTRACT DOCUMENTS:

The priority list of contractual documents shall be as follows:

- (a) Contract Agreement;
- (b) Letter of Acceptance;
- (c) Specifications and Employer Design
- (d) Contract Data;
- (e) Conditions of Contract;
- (f) Letters Technical Bid and Price Bid;
- (g) The priced Bill of Quantities; and
- (h) The Appendices to Bid.

Special Conditions of Contract

Notes on the Special Conditions of Contract Similar to the Bid Data the clauses in this Section are intended to assist the Procuring agency in providing contract-specific information in relation to corresponding clauses in the General Conditions of Contract.

The provisions of Section III ,Special Condition are complement to the General Conditions of Contract , specifying contractual requirements linked to the special circumstances of the Procuring agency, the Procuring agency's country, the sector, and the Goods purchased. In preparing special conditions, the following aspects should be checked:

- a. Information that complements provisions of General Condition of Contract GCC must be incorporated.
- b. Amendments and/or supplements to provisions of GCC, as necessitated by the circumstances of the specific purchase, must also be incorporated

SPECIAL CONDITIONS OF CONTRACT

The following Special Conditions of Contract shall supplement & qualify the General Conditions of Contract (GCC). Whenever there is a conflict, the provisions herein shall prevail over those in the General Conditions of Contract. The corresponding clause number of the GCC is indicated in parentheses.

| GCC Ref No | | |
|------------------------|-------|---|
| 1. DEFINITIONS | 1.1 g | The Procuring agency is: Institute of Business Administration IBA karachi |
| | 1.1 h | The Procuring agency's country is: Pakistan |
| | 1.1 i | The Vendor is: i. Manufacturer and/or Importer registered with relevant sales and income tax authorities and have requisite qualification and eligibility for supply of Goods in the specialized categories of Fire Safety; |
| | 1.1 j | The Project Site is: Institute of Business Administration IBA karachi Main Campus Karachi University Enclave |
| 3 COUNTRY OF ORIGIN | | All countries and territories as indicated in the bidding documents Eligibility for the Provisions of Goods, Works, and Services in Government Financed Procurement. The bidder will provide the details regarding country of origin, Model, Make, manufacturer, along with details of Manufacturing Units and mode of supply, shipment, and any other associated details of the component items and that of the quoted equipment. Bidders are bound to supply the equipment from quoted country of origin only. |
| 7.PERFORMANCE SECURITY | 7.1 | <ul style="list-style-type: none"> • The Supplier shall, within 14 days of receipt of Award Letter, provide a Performance Security for the due performance of the Contract to the amount of ten (5%) of contract price in shape of Call Deposit Receipt (CDR) or Bank Guarantee, at the option of bidder, in the name of Institute of Business Administrative IBA Karachi from schedule bank of Pakistan; • Failure of the successful Bidder to submit the requisite performance security or to sign the contract agreement shall constitute sufficient grounds for the annulment of the award and forfeiture of the bid security. In that event, the Client may award the contract to the next lowest evaluated bidder whose offer is substantially responsive. • The proceeds of the Performance Security shall be payable to the Purchaser as compensation for any loss resulting from the Supplier's failure to complete its obligations under the Contract. The Performance Security shall be discharged by the Purchaser and returned to the Supplier not later than 28 days following the |

| | | |
|----------------------------|-------------------------------------|--|
| | | date of completion of the Supplier's performance obligations under the Contract, including any warranty obligations. |
| 8. INSPECTIONS AND TESTS | 8.6 | <p>i. The Technical Evaluation shall be conducted by the Technical and Evaluation (T&E) Committee to undertake verification of documents submitted by the bidder/s along with the technical bids as well as to conduct the physical inspection of the various samples/relevant premises as per Technical Specification of the Bidding Documents</p> <p>ii. Sample tests as well as pre-shipment inspections will also be carried out as and when needed before signing of contract agreement with all the successful bidders for Machinery & Equipment, instruments etc.</p> |
| 9. PACKING | | In accordance with the GCC Clause 9 as well as provided in the relevant clauses of contract agreement . |
| 10. DELIVERY AND DOCUMENTS | | <p>Applicable Delivery Mode:</p> <p>Delivered Duty Paid (DDP) as per contract agreement of the Successful with the Procuring Agency. The delivery, loading/unloading and installation will be responsibility of bidder. No charges will be paid additionally in case of penalty or any other charges.</p> |
| 15. WARRANTY | <p>15.1</p> <p>15.2</p> <p>15.4</p> | <p>The Vendor shall provide warranty as per the terms and conditions of the Rate Contract Agreement with Procuring Agency</p> <p>In partial modification of the provisions, the warranty period shall be as per contract terms and conditions. The vendor shall, in addition, comply with the performance and/or consumption guarantees specified under the Contract. If, for reasons attributable to the vendor, these guarantees are not attained in whole or in part, the vendor shall, at its discretion, either:</p> <p>a. Make such changes, modifications, and/or additions to the Goods or any part thereof as may be necessary in order to attain the contractual guarantees specified in the Contract at its own cost and expense and to carry out further performance tests in accordance with SCC</p> <p>b. . Pay liquidated damages to the Procuring agency with respect to the failure to meet the contractual guarantees. The rate of these liquidated damages shall be higher than the adjustment price used in bid evaluation.</p> <p>The period for correction of defects in the free warranty period is Five years after installation with free parts and free services, including all incidental charges</p> |
| 16. PAYMENT | 16.1 | <p>The method and conditions of payment to be made to the Supplier under this Contract shall be as follows:</p> <p>i. GCC Clause 16 as well as under the terms and condition in Contract Agreement with the Procuring Agency, the goods supplied under the Contract shall be delivered duty paid (DDP) and inclusive of all taxes</p> |

| | | |
|----------------------------|------|--|
| | | <p>etc. Payment shall be made in Pak. Rupees in accordance with the relevant and applicable government rules and regulations</p> <p>On Shipment: Eighty (80) percent of the Contract Price of the Goods delivered at Site shall be paid after duly verification by the Engineer Incharge.</p> <p>ii. Payment shall not be made for partial and incomplete supply of goods.</p> |
| 17. PRICES | 17.1 | <p>i. In case the bid price is higher than estimated cost, the Procuring agency has the right to reject the bid and scrap the process without any liability.</p> <p>ii. In case of single bid after technical evaluation, the procuring agency may carry out the market analysis before issuing a letter of consent to the successful bidder.</p> |
| 23. LIQUIDATED DAMAGES | | As in relevant clauses of the Contract Agreement signed by the Supplier with the Procuring Agency. Penalties shall be imposed as per contract agreement and blacklisting & debarment guidelines of the department if the firm deviates from Contract Agreement |
| 28. RESOLUTION OF DISPUTES | | <p>The dispute resolution mechanism to be applied will be pursuant to relevant clauses of Contract Agreement signed by Supplier with the Procuring Agency under SPPRA If at all required, the jurisdiction of Court shall be of Karachi, Sindh.</p> <p>Bid Tie. In case of tie in the final score of two bidders, and unless otherwise not in contradiction to any of the terms & conditions and specifications of that item, the rate contracting will be offered to the bidder having higher score in its technical bid and the same will be declared as highest fair bid (successful bidder).if technical and financial score are the same, the contract may be awarded to both firms.</p> |
| 29. GOVERNING LANGUAGE | 29.1 | The Governing Language shall be: English |
| 30. APPLICABLE LAW | 30.1 | <p>The Contract shall be interpreted in accordance with the laws of Islamic Republic of Pakistan, which includes the following legislation:</p> <p>i. The SPPRA Act 2012</p> <p>ii. The SPPRA Rules 2014</p> <p>iii. The Contract Laws</p> <p>iv. The General Financial Rules of the Govt. of Sindh and all the Relevant laws, rules and regulations pertaining to budgeting & financial management of public fund</p> <p>iv. . The Bonded Labor System (Abolition) Act of 1992</p> |

| | | |
|-------------------|------|---|
| | | v. The Factories Act 1934 |
| 31. NOTICES | 31.1 | <p>Procuring Agency address for notice purposes: Registrar Institute of Business Administration IBA Karachi University of Karachi Enclave Karachi Pakistan. Email: www.iba.edu.pk</p> <p>Supplier's address for notice purposes: As mentioned in their bidding document</p> |
| 32 Duties & Taxes | 32.1 | <p>The Unit price quoted by the bidder shall be: inclusive of all applicable duties and taxes. All prices shall include relevant taxes & duties, where applicable. The benefit of exemption from or reduction in the GST or other taxes shall be passed on to the Procuring Agency.</p> |

CONTRACT DATA
Conditions of Contract

| Sr. # | Description | Clause Conditions of Contract | Explanation |
|--------------|----------------------------------|--------------------------------------|---|
| 1. | Employer's name and address | 1.1.4 | Institute of Business Administration (IBA) Karachi IBA Main campus University of Karachi Enclave Karachi |
| 2. | Contractor's name | 1.1.5 | [Name of the Successful Bidder] |
| 3. | Commencement Date | 1.1.7 | Commencement Date shall be the date when all of the following conditions have been fulfilled: 1. The Contractor has submitted to the Employer the Performance guarantee in accordance with the terms of Conditions of the Contract; |
| 4. | Site | 1.1.17 | IBA Main Campus University of Karachi Enclave Karachi |
| 5. | Engineer's name and address | 1.1.20 | Project Department IBA Karachi Main Campus University of Karachi Enclave Karachi |
| 6. | Access to site | 2.1 | Within two (2) days of signing of Contract |
| 7. | Subcontracting | 4.3 | The aggregate amount of the works subcontracted shall not exceed 20% of the Contract. |
| 8. | Amount of Performance Security | 4.4 | Five (5%) of Contract Price stated in the Letter of Acceptance. |
| 9. | Validity of Performance Security | 4.4 | Validity of Performance Security shall be Twelve (12) months from the issuance of Taking Over Certificate (TOC) and, if not uncashed pursuant to the terms of the Contract, shall be returned within fourteen (14) days of its expiry. |
| 10. | Time for Completion | 7.1 | One hundred twenty (120) days from the Commencement Date. |
| 11. | Time for furnishing Programme | 7.2 | Within seven (7) days from the date of receipt of Letter of Acceptance. |
| 12. | Amount of Liquidated Damages | 7.4 | The rate of the Liquidated Damages (LD) shall be 0.05% of the Contract Price stated in the Letter of Acceptance for every week of delay in which whole or part of the work(s) remained unfurnished subject to a maximum of 10% of the Contract Price. |
| 13 | Defects Liability Period | 8.3 | One year calculated from the date of Taking Over Certificate issued by the Employer. Defect Liability Certificate shall be issued within 14 days after Defect Liability Period. |

Contract Data

| | | | |
|-----|-------------------------|-----|---|
| 14. | Remedying Defect Period | 9.1 | Within fourteen (14) days after notice of defect. |
|-----|-------------------------|-----|---|

| | | | |
|-----|---------------------|------|--|
| 15. | Contract Price | 11.1 | As stated in the Letter of Acceptance. |
| 16. | Payment Terms | 11.2 | <p>(i) <u>Advance Payment:</u> Ten percent (10%) of the Contract Price which shall be released by the Employer within fifteen (15) working days upon receipt and verification of Advance Payment Guarantee from the Contractor, as per the form provided in the Bidding Documents, of an amount equivalent to Ten percent (10%) of the Contract Price, issued by any Scheduled Bank of Pakistan in favour of the Employer. Such Advance Payment Guarantee shall be posted by the Contractor no later than five (20) working days of execution of the Contract Agreement.</p> <p>(ii) <u>Second Partial Payment:</u> Seventy five percent (75%) of the Contract Price which shall be released to the Contractor by the Employer upon delivery of machinery, equipment and material forming the System at the Site and certificate from the Engineer confirming the quantity and conformity of the equipment with the approved Contractor Design.(Advance payment made to the contractor shall be adjust from these payments made)</p> <p>(iii) <u>Final Payment:</u> Twenty percent (20%) of the Contract Price which shall be released to the Contractor by the Employer upon the date of the issuance of Taking Over Certificate. (Advance payment made shall be deducted from payment)</p> <p>iv) <u>Retention Amount</u> 10 % of the Contract Price shall be deducted from each payment and shall be released upon completion of the Defects liability Period along with performance guarantee.</p> |
| 17. | Seat of Arbitration | 15.3 | Karachi |

Contract Data

LETTER OF TECHNICAL BID

Date: -----

Bid Reference No: _____

(Name of Contract/Works)

To:

[Head of the Procuring Agency/Employer] [Employer’s Address]

We, the undersigned, declare that:

- (a) We have examined and have no reservations to the Bidding Documents, including Addenda issued in accordance with instructions to Bidders (IB) 9;
- (b) We offer to execute and complete in conformity with the Bidding Documents the Works (as defined in the Bidding Documents);
- (c) Our Bid consisting of the Technical Bid and the Bid Price shall be valid for a period of ninety (90) days from the date fixed for the bid submission deadline in accordance with the Bidding Documents, and it shall remain binding upon us and may be accepted at any time before the expiration of that period;
- (d) As security for due performance of the undertakings and obligations of our bid, we hereby submit a Bid Security, in the amount specified in Bidding Data, which is valid (at least) thirty (30) days beyond validity of Bid itself;
- (e) We confirm that our Bid is not in deviation of any technical and commercial terms as provided in the Bidding Documents;
- (f) We are not participating, as a Bidder or as a subcontractor, in more than one bid in this bidding process; and
- (g) We agree to permit Employer or its representative to inspect our accounts and records and other documents relating to the bid submission and to have them audited by auditors. This permission is extended for verification of any information provided in our Technical Bid which comprises all documents enclosed herewith in accordance with IB 11.1 of the Bidding Data.

Name-----

In the Capacity of-----

Signed-----

Duly authorized to sign the Bid for and on behalf of:-----

Date:-----

Address:-----

Letter of Technical Bid

LETTER OF PRICE BID

Date: _____

Bid Reference No: _____

(Name of Contract/Works)

To:

[Head of the Procuring Agency/Employer] [Employer’s Address]

We, the undersigned, declare that:

- a. We have examined and have no reservations to the Bidding Documents, including Addenda issued in accordance with instructions to Bidders (IB) 9;
- b. The total price of our Bid, including any discounts offered, is PKR [●];
- c. Our Bid shall be valid for a period of ninety (90) days from the date fixed for the bid submission deadline in accordance with the Bidding Documents, and it shall remain binding upon us and may be accepted at any time before the expiration of that period;
- d. If our Bid is accepted, we commit to obtain and post a Performance Security in accordance with the Bidding Documents;
- e. We understand that this bid, together with your written acceptance thereof included in your notification of award, shall constitute a binding contract between us, until a formal contract is prepared and executed and we do hereby declare that the Bid is made without any collusion, comparison of figures or arrangement with any other bidder for the works;
- f. We understand that you are not bound to accept the lowest evaluated bid or any other bid that you may receive; and
- g. If awarded the contract, the person named below shall act as Contractors Representative.

Name -----

In the capacity of -----

Signed -----

Duly authorized to sign the Bid for and on behalf of -----

Date -----

Address -----

APPENDICES TO BID

PROPOSED CONSTRUCTION SCHEDULE

[Please note that the Works shall be completed within the time period stated in the Contract Data. The Bidder shall provide as Appendix-A to Bid, the Construction Schedule in the bar chart (CPM, PERT or any other to be specified herein) showing the sequence of work items and the period of time during which he proposes to complete each work item in such a manner that his proposed programme for completion of whole of the Works and parts of the Works shall not exceed the time period specified in the Contract Data. Such period shall commence and counted from the Commencement date as specified in the Contract Data.]

LIST OF SUBCONTRACTORS

[Name of Bidder] intend to subcontract the following parts of the Works to subcontractors. We hereby confirm that the subcontractors named hereunder are reliable and competent to perform that part of the Works for which each is listed.

Please find enclosed the documentation outlining experience of the subcontractors, the curriculum vitae and experience of their key personnel who will be assigned to the Contract, equipment to be supplied by them, size, location and type of contracts carried out in the past.

| Part of Works (Give Details) | Subcontractor (With Complete Address) |
|---|--|
| 1 | 2 |
| | |

Appendix-C to Bid

PAST EXPERIENCE, PERSONNEL CAPABILITIES AND FINANCIAL STRENGTH

Please provide requisite documentary evidence to substantiate the past experience, personnel capabilities and financial strength of the Bidder for evaluation as per the Qualification Criteria given below:

| Sr. # | Category | Criteria | Required Documents |
|-------|--------------------|--|---|
| I. | Experience Record | Fire Hydrant System completed in last two years (as main contractor, JV and sub-contractor) | As per EXP-1 Form |
| II. | Financial Strength | Average Annual Turnover of minimum PKR 10 million in last two years. Minimum average Net Worth of PKR 20 million in last two years. | Audited Financial Reports of last two years |

Note:

i. Qualification status shall be decided on Pass / Fail basis. ii. In case of JV, all the members shall collectively comply / qualify the Qualification requirements as specified above.

**Form EXP-1:
Details of Contracts of Similar Nature and Complexity**

| |
|---|
| <i>Name of Bidder or partner of a joint venture</i> |
|---|

Use a separate sheet for each contract

| | |
|----|--|
| 1. | Name of Contract |
| | Country |
| 2. | Name of Employer |
| 3. | Employer Address & Contact Details |
| 4. | Nature of Works |
| 5. | Contract Role (Tick One) (a) Sole Contractor (b) Sub- Contractor (c) Partner in a Joint Venture |
| 6. | Capacity & Value (PKR) of the total contract. |
| 7. | Date of Award |
| 8. | Date of Completion |
| 9. | Contract Duration (Years and Months) |

Note: The Bidder shall attach documentary evidence (contract agreement & completion certificate) to substantiate the above facts/data.

Appendix-D to Bid

JOINT VENTURE AGREEMENT

[Please provide certified true copy of Joint Venture (JV) Agreement, if applicable.]

INTEGRITY PACT

**DECLARATION OF FEES, COMMISSION AND BROKERAGE ETC.
PAYABLE BY THE SUPPLIERS OF GOODS, SERVICES & WORKS IN
CONTRACTS WORTH RS. 10.00 MILLION OR MORE**

Contract No. _____ Dated _____

Contract Value: _____

Contract Title: _____

..... [name of Contractor] hereby declares that it has not obtained or induced the procurement of any contract, right, interest, privilege or other obligation or benefit from Government of Pakistan (GoP) or any administrative subdivision or agency thereof or any other entity owned or controlled by GoP through any corrupt business practice.

Without limiting the generality of the foregoing, [name of Contractor] represents and warrants that it has fully declared the brokerage, commission, fees etc. paid or payable to anyone and not given or agreed to give and shall not give or agree to give to anyone within or outside Pakistan either directly or indirectly through any natural or juridical person, including its affiliate, agent, associate, broker, consultant, director, promoter, shareholder, sponsor or subsidiary, any commission, gratification, bribe, finder's fee or kickback, whether described as consultation fee or otherwise, with the object of obtaining or inducing the procurement of a contract, right, interest, privilege or other obligation or benefit in whatsoever form from GoP, except that which has been expressly declared pursuant hereto.

[name of Contractor] certifies that it has made and will make full disclosure of all agreements and arrangements with all persons in respect of or related to the transaction with GoP and has not taken any action or will not take any action to circumvent the above declaration, representation or warranty.

[name of Contractor] accepts full responsibility and strict liability for making any false declaration, not making full disclosure, misrepresenting facts or taking any action likely to defeat the purpose of this declaration, representation and warranty. It agrees that any contract, right, interest, privilege or other obligation or benefit obtained or procured as aforesaid shall, without prejudice to any other rights and remedies available to GoP under any law, contract or other instrument, be voidable at the option of GoP.

Notwithstanding any rights and remedies exercised by GoP in this regard, [name of Contractor] agrees to indemnify GoP for any loss or damage incurred by it on account of its corrupt business practices and further pay compensation to GoP in an amount equivalent to ten times the sum of any commission, gratification, bribe, finder's fee or kickback given by [name of Contractor] as aforesaid for the purpose of obtaining or inducing the procurement of any contract, right, interest, privilege or other obligation or benefit in whatsoever form from GoP.

Name of Employer:

Name of Contractor:

Signature:

Signature:

[Seal]

[Seal]

Appendix-F to Bid

PROOF OF PURCHASE OF RFP

[Please provide certified true copy of purchase of RFP from the Employer]

Appendix-G

Appendix-H

DECLARATION OF BENEFICIAL OWNERS

The “**Declaration of Beneficial Owners**” Information of Public Procurement Contract Awarded Regulations, 2022” require that all procuring agencies while engaging in public procurement contract worth Rs. 50 Million and above shall make a mandatory provision of beneficial ownership information of the company in the said contract as prescribed in following performa to these regulations. The procuring agencies while entering into such contracts shall publicize the beneficial ownership information of the company on PPRA’s website. The procuring agency shall forward all such contracts containing the beneficial ownership information to the Authority for placing it on PPRA’s website. Accordingly, if applicable, the following performa shall be submitted by the bidders along with the Technical Bid.

DECLARATION OF ULTIMATE BENEFICIAL OWNERS INFORMATION FOR PUBLIC PROCUREMENT CONTRACTS.

1. Name

2. Father's Name / Spouse's Name _____

3. CNIC / NICOP / Passport No. _____

4. Nationality _____
5. Residential Address
6. Email Address
7. Date on which shareholding control or interest acquired in the business

8. In case of indirect shareholding control or interest being exercised through intermediary companies, entries or other legal persons or legal arrangements in the chain of ownership or control following additional particulars to be provided:

| | | | | | | | | | |
|---|---|---|---|---|---|---|---|---|----|
| 1 | 2 | 3 | 4 | 5 | 6 | 7 | 8 | 9 | 10 |
|---|---|---|---|---|---|---|---|---|----|

| Name | Legal form (company)/ limited liability partnership / association of persons / Single Member company / partnership firm / trust any other individual body corporate (to be specified) | Date of incorporation / registration | Name of registering authority | Business Address | Country | Email Address | Percentage of shareholding control or interest of BO in the legal person or legal arrangement | Percentage of shareholding control or interest of legal person or legal arrangement in the company | Identity of natural person who ultimately owns or controls the legal person or arrangement |
|------|--|--------------------------------------|-------------------------------|------------------|---------|---------------|---|--|--|
| | | | | | | | | | |

9. Information about the Board of Directors (Details shall be provided regarding number of shares in the capital of the company as set opposite respective names).

Part-II The Gazette of Pakistan Extra

| | | | | | | | |
|---|---|---|---|---|---|---|---|
| 1 | 2 | 3 | 4 | 5 | 6 | 7 | 8 |
|---|---|---|---|---|---|---|---|

| Name and Surname (in Block Letters) | CNIC No. (in case of foreigner passport No) | Father's / Husband's name in full | Current Nationality | Any other Nationality (ies) | Occupation | Residential address in full of the registered / principal office address for a subscribers other than natural person | Number of shares taken by cash subscriber (in figures and words) |
|-------------------------------------|---|-----------------------------------|---------------------|-----------------------------|------------|--|--|
| | | | | | | | |

10. Any other information incidental to or relevant to Beneficial owner(s)

Name and Signature
(Person authorized to issue notice on behalf of the company)

Appendix-I

AFFIDAVIT OF BLACKLISTING

[Please provide an affidavit that the bidder has not been blacklisted by any government / public department / donor agencies at the time of submission of bid.]

Appendix-J

EVALUATION CRITERIA

MANDATORY CRITERIA

Following are the mandatory criteria and should be submitted along Technical bid:

1. The firm should have valid registration with PEC in category C-6 and above with relevant specialization category of M-02.

2. The firm should have valid and active NTN, GST and SRB.
3. The firm shall submit the Technical Data Sheet of the Proposed equipment and it should be in Compliance with NAFP -20 and this data sheet should be submitted with Technical Bid.
4. The bidder shall submit a confirmation certificate from the manufacturer /distributor of the equipment proposed that spare parts of the proposed equipment shall be available in next ten years from the date of installation /supply of equipment
5. The bidders shall submit an affidavit that the vendor is not black listed with any Federal/Provincial Organization /Institution
6. The bidder shall submit an affidavit for no litigation and if there is any the detail must be submit.

If any of the above information is missing then the firm shall be disqualified without any further proceeding.

**Evaluation Criteria Total Marks (Technical Criteria + Financial Criteria):
TM: 70 + 30 =100**

1. Applicant has to score minimum 50 %marks to get Technical qualified in each criteria i.e. Technical & Financial ;
2. Applicant must provide all the required documents as an evidence against each evaluation criteria.

| S. NO | Category | Max Marks |
|----------|---|-----------|
| | TECHNICAL CRITERIA | 70 |
| A. | Organizational Profile | 15 |
| 1 | Nature of Business (Registration certificate /Documentary Evidence) | 5 |

| | | | |
|-----------|--|--------------|-----------|
| a | Private limited firm | 5 Marks | |
| b | Partnership | 3 Marks | |
| c | Proprietor Ship | 2 marks | |
| 2 | Office Set Up (Documentary Evidence) | | 5 |
| a | Having registered office in Karachi | 5 marks | |
| b | Having registered office in other city of Pakistan | 3 marks | |
| 3 | Life Span of Business (First PEC registration date) | | 5 |
| a) | Established 5 yrs or more | 5 marks | |
| b) | Established less than 5 Years but 2 or more | 3 marks | |
| c) | Established less than 2 years | 0 marks | |
| B | Experience of Similar Fire Fighting Projects(Compl. Cert. or PO) | | 40 |
| 1. | Completed Projects during last 5 Years | | 25 |
| a) | Projects Completed by the firm or the Engineer associated with the firm 10 Marks for each | max.25 marks | |
| 2 | Projects in Hand (Work Order or PO) | | 10 |
| a) | Projects in hand 10 marks each project | max10 marks | |
| C | Personnel Capabilities (Copy of Degree /Diploma) | | 15 |
| 1) | No. of Eng. with 5 yrs or more exp. 10 marks for each | max 10 | 10 |
| 2) | No of DAE(Elect/Mech) with 5 Yrs exp.5 marks for each | max5 | 5 |
| D | Warranty (Documentary Evidence) | | 5 |
| 1) | Warranty with parts and services from original manufacturer for 10yrs or more | 5 | |
| 2) | Warranty with parts and services from original manufacturer for 5yrs | 3 | |
| | FINANCIAL CRITERIA | | 30 |
| A | Average Annual Turn over as per Audit report /Bank Statement | | |
| 1 | Av. turn over during the last 3 years equal or more than 20 Mill | 30 Marks | |
| 2 | Av. turn over during the last 3 years less than 20 Mill upto10 mill | 20 Marks | |
| 3 | Av. turn over during the last 3 years less than 10 Mill up to 8 mill | 15 Marks | |
| | | | |
| | | | |

Appendix-K

TECHNICAL SPECIFICATION

SECTION -1 FIRE PUMP SET (1E+1J) for Duty Point: 500 US GPM @ 8 Bar

General : The water based Fire Suppression System is served by a Fire Pump sets consisting of an Electric Motor operated at Fire Pump and a Jockey Pump with individual Controllers. Fire pumps should be manufactured in line with EN 12845, European Union Standard, and NFPA 20 in order to fulfill national and international demands. General Properties of Fire Pump Systems in accordance with NFPA 20 are as follows :

Fire Pumps: End Suction Centrifugal type as per EN 733 Electrical Motor Driven

Capacity : 500 US GPM

Head : 8 Bar pressure

H (max) / Cut off Head : 8.8 bar

Power : 60 HP 45 KW

Voltage : 380v / 3phase/ 50 hz

Protection Degree : IP 55

Casing : Grey cast Iron

Impeller : Bronze DN : 240mm

Shaft : Stainless Steel SS 304

Bearing : NSK Bearing with Wearing Resistant Mechanical Seal

Motor Winding Insulation Class : S

Power Connection : Star Delta

Current : 83.9 / 48.4

Pump case with Anti Corrosive Paint Easily pull back from driver

Jockey Pump : SS 304 Vertical Multistage Centrifugal Pump

Capacity : 50 US GPM

Head : 9 Bar pressure

H (max) / Cut off Head : 108 Meters

Power : 7.5 HP 5.5 KW

Voltage : 220~ 380v / 3phase/ 50 hz

Protection Degree : IP 55

Casing : Grey cast Iron

Impeller : SS 304

Shaft : Stainless Steel SS 304

Bearing : NSK Bearing with Wearing Resistant Mechanical Seal

Motor Winding Insulation Class : S

Power Connection : D.O.L

Current : 11.1 / 6.4

Duty : SI Continuous

FIRE PUMP CONTROLLER

. Typical Specifications

1. Approvals

. The Fire Pump Controller shall meet the requirements of the latest edition of NFPA 20 and shall be listed by [Underwriters Laboratories (UL)]and approved by [Factory Mutual Research (FM)] and carry the CE marking for fire pump service

Starting Type A.

The controller shall be of the combined manual and automatic type.

Ratings A.

The Controller shall have a withstand rating of 100,000 RMS symmetrical amperes

4. Construction

A. The controller shall include a motor rated combination isolating switch and circuit breaker, mechanically interlocked and operated with a single externally mounted handle.

B. The isolating switch shall be rated to disconnect the motor load.

C. The isolating switch/circuit breaker combination shall be mechanically interlocked such that the enclosure door cannot be opened when the handle is in the on position except by a tool operated defeater mechanism.

5. Enclosure A.

The controller shall be housed in a NEMA Type 4X (IEC IP 66) water tight corrosion resistant , powder baked finish, freestanding enclosure.

6. Microprocessor Control

A. The controller shall come complete with a 4 line by 40 character LCD display mounted on a panel opening in the front door. The LCD display shall indicate the following:

1. Main screen displaying system pressure, three phase voltage and amperage readings, system frequency, date, and time.

2. Set point review screen displaying the programmed pressure start and stop points, and weekly test time.

3. Controller statistics screen

4. Controller diagnostics screen,
5. Display last messages screen that will display up to 10,000 alarms/messages stored in the controllers' memory.
6. Display up to ten (10) custom messages of up to 100 characters each, which will continually scroll across the fourth line of the display.
7. Remaining time left on active timers.

B. The controller shall be supplied with ten (10) green status LED's for the following:

1. Power On
2. Pump Running
3. Local Start
4. Remote Start
5. Deluge Valve
6. Emergency Start
7. Interlock On
8. Low Pressure
9. Auto Shutdown Enabled
10. Programmable LED #1

C. The controller shall be supplied with ten (10) red alarm LED's to indicate the following:

1. Phase Reversal
2. Phase Failure
3. Fail to Start
4. Undervoltage
5. Overvoltage
6. Low Room Temperature
7. Locked Rotor Trip
8. Low Suction Pressure
9. Source 2 Disconnected
10. Programmable LED #2

D. The microprocessor logic board shall be available with:

1. A USB port for transference of message history, controller status, diagnostics, and statistics and the ability to update firmware.
2. An optional Ethernet port for direct connection to a computer for data transfer.
7. Programming Menu

- A. The programming menu shall have the ability to enable an entry password.
- B. The programming menu shall be limited to two (2) levels of password protection.
- C. The controller shall have one (1) languages as a standard, English
- D. The programming menu shall be grouped into 6 main menu headings as follows:

- 1. Regional Settings
- 2. Pressure Settings
- 3. Timer Values
- 4. Alarm Set points
- 5. Input/Output Menu
- 6. System Configuration (password protected)

8. Pressure Sensor

A solid-state 4-20mA pressure sensor shall be provided.

9. Custom Inputs/Outputs

A. The controller shall come standard with nine (9) future inputs, two (2) future LED indicators, and one (1) future output, with the ability to add up to another 8 outputs via optional relay boards.

B. The user shall be able to program the future inputs/outputs through the main programming menu.

C. The inputs shall be selectable based on the following criteria criteria:

10. Alarm Relays

A. All relays shall be of the plug-in type. An LED on the relay panel shall indicate the energized state of the relay. All relay contacts shall be rated @ 8A, 277VAC/30VDC. Two (2) sets of Form-C contacts shall be provided for each of the following:

- 1. Phase Reversal
- 2. Phase Failure
- 3. Common Alarm
- 4. Future #1
- 5. Pump Run.

B. The Common Alarm and Phase Failure relays shall be energized under normal conditions.

11. Audible Alarm Buzzer

An audible alarm buzzer, capable of being heard while the motor is operating, shall operate if Fail to Start, Hardware Malfunction or any Common Alarm condition exists.

12. Manufacturer A.

The controller shall be of the LMR Plus type as manufactured by TornaTech,, Eaton Turkey or equivalent in compliance to NFPA-20 Latest Edition.

C. Jockey Pump Controller:

1. Approvals

a) The Jockey Pump Controller shall meet the requirements of UL 508 (Underwriters Laboratories UL).

2. Starting Type

a) The controller shall be across the line or Wye-Delta type designed for full voltage starting.

3. Ratings

a) The Controller shall have a minimum withstand Rating of 10,000 symmetrical amperes . The horsepower rating of the controller shall not exceed 50Hp for three (3) phase units or 10Hp on single phase units.

4. Construction

The controller shall include a combination Circuit Breaker / Overload Motor Protector. The motor circuit protector shall be mechanically interlocked such that the enclosure door cannot be opened when the handle is in the on position except by a tool operated defeater mechanism. The controller manufacturer shall manufacture the contactor, motor circuit protector, touchscreen display, and enclosure. Brand-labeled components will not be accepted.

5. Supply Voltage

a) The Jockey pump controller shall be suitable for 400V/3/50Hz.

6. Enclosure

a) The controller shall be housed in a NEMA Type 4X (IEC IP66) Water Tight Anti Corrosive, powder baked finish, freestanding enclosure.

7. Run Period Timer

a) An optional Run Period Timer shall be provided.

8. Languages

a) The controller shall have English language as standard.

9. Digital Indication

a) The controller shall be supplied with a digital display that shall indicate the following: System Pressure, Start Pressure, Stop Pressure.

b) The digital display shall be supplied with a solid-state 4-20mA pressure sensor. The pressure Start and Stop points shall be adjustable in increments of one (1) PSI.

c) The digital display shall be a door-mount type that permits exterior programming with the controller door secured.

10. Options

a) The Jockey pump controller shall also be provided with the following:

i. Contacts for "Pump Run"

ii. Contacts for "AC Power Failure"

iii. "Power On" Light

iv. "Pump Run" Light

v. Low Suction Pressure Switch and Alarm Pilot Light

vi. Low Suction Shutdown

vii. Elapsed Run Time Meter

12.Spares: The Contractor shall supply spares for each of the fire pumps and Controllers suitable for 3 years of normal operation in accordance with the manufacturer's recommendations. An "Operation and Maintenance" manual shall be supplied with the fire pump set.

13 EXECUTION

A) Installation: Installation of the fire pumps shall be carried out by Installation Contractor and are not covered in the scope of work of this Contractor. This Contractor shall however provide periodical supervision services and ensure that the installation is being carried out in accordance with manufacturer's recommendations and requirements. This Contractor shall also provide all assistance to the Installation Contractor to facilitate the installation of the Fire Pumps and Controllers.

B) Commissioning and Testing: The Fire Pumps shall be commissioned and tested by the Contractor, in accordance with the manufacturer's recommendations.

a)Testing at Manufacturers Works

The Fire Pumps & Controllers shall be subjected to testing at the manufacturer's works, to determine conformance to NFPA 20 requirements and FM approval standards. All test reports shall be supplied by the Manufacturer to the Employer.

The pump operational curve shall be identified by taking no-flow reading and shall be charted on the pump curve. Operational point at full flow shall be identified and submitted to the Consultant. Tests shall be conducted and test reports submitted to the Consultant and approval obtained

b) Testing at Site

The Supplier shall carry out complete testing of the fire pump sets after the completion of installation and in accordance with manufacturer's recommendations and shall record the commissioning and testing of the fire pumps in the Testing and Commissioning Forms attached as annexure to these specifications.

As part of the testing Supplier shall plot the pump performance on the manufactures' certified pump test curves showing head capacity and brake horsepower of the pump, and shall prove conformance of operation to rated data.

The testing shall be done by activating the individual fire pumps in the same operating sequence that will be actually implemented.

c) Warranty

Manufacturer shall guarantee all components of the fire pumps against defects in materials and/or workmanship for a period of 18 months from date of initial operation or 24 months from data of shipment, whichever occurs first, unless otherwise stated elsewhere in this document.

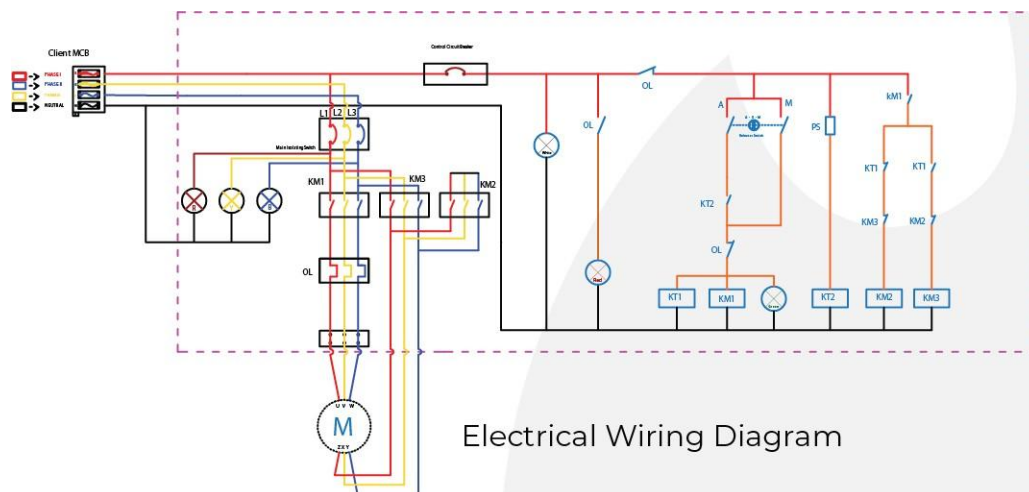

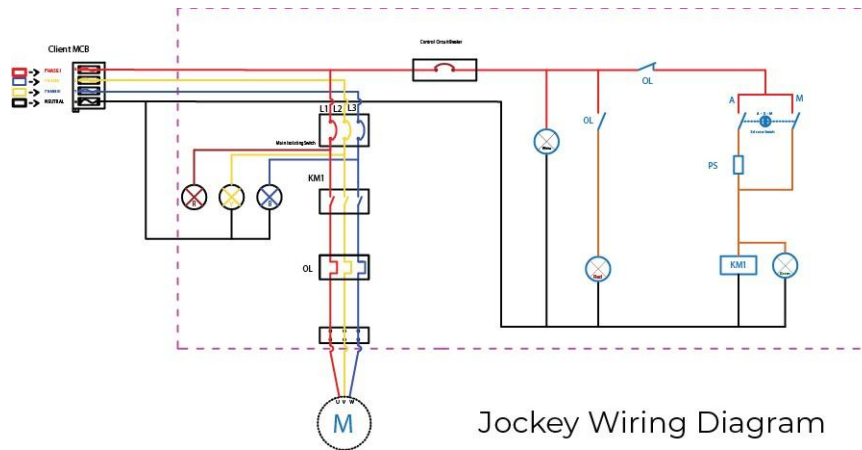

CHAPTER – 2 ABOVE GROUND FIRE SUPPRESSION PIPING & SPECIALITIES

Part -1 GENERAL

a) Scope: . This Section covers the scope of supply and installation of all above ground piping to conduct fire water for fire suppression system.

The Contractor shall supply and install all fire water piping as shown on the drawings and in accordance with these specifications.

B) General Requirements

- i). Minimum Pressure Rating for Standard-Pressure Piping: 175 psig.
- ii). Minimum Pressure Rating for High-Pressure Piping: 300 psig.

C) Reference Standards

- a) . NFPA 14 Standard for the installation of Standard-pipe and hose systems.

D Submittals:

a). Tendering Stage Submittal

- i) . Indicate the pipe sourcing and manufacturer.

b). Construction Stage Submittal

- i). Provide all technical details of piping and fittings
- b).Submit samples of pipes and fittings.

E Quality Assurance:

- i). All piping and fittings shall be supplied preferably by one manufacturer.
- ii) Delivery, Storage, and Handling:

Pipes shall be stored and handled in accordance with the manufacturer's recommendations. Protect internals from entry of foreign material by temporary caps on openings.

PART-2: PRODUCTS

i) Piping Material:

- a) Seamless Black Steel Piping: Schedule 40 conforming to ASTM A53. . Pipe ends may be factory or field formed to match joining method.
- b) Steel Couplings: ASTM A 865, threaded.
- c) Gray-Iron Threaded Fittings: ASME B16.4, Class 125, standard pattern.
- d) Malleable- or Ductile-Iron Unions: UL 860.
- e) Cast-Iron Flanges: ASME 16.1, Class 125.
- f) Steel Flanges and Flanged Fittings: ASME B16.5, Class 150.

2 Fittings & Flanges:

Fittings shall be forged, compatible to the pipe. Welded fittings shall be butt-welding type. Galvanised piping shall be provided with galvanised fittings with threads. All fittings shall be rated for minimum 10 bars SWP. B. Flanges shall be slip-on type & shall conform to ANSI B16.5. Galvanised piping shall be provided with galvanised threaded flanges. All flanges shall be rated for minimum 10 bars SWP. C. All joints shall be welded, except the sprinkler fitting.

3 Suspended Piping Supports:

- a) Piping shall be supported by adjustable hangers or supports, which shall provide a means of vertical adjustment after erection as per the manufacturer recommendation (Contractor to provide details, calculation & analysis of support system)
- b) Pipes passing through concrete or masonry walls or concrete floors or roofs shall be provided with pipe sleeves fitted into place at the time of construction or afterwards if necessary. Each sleeve shall extend through its respective wall, floor or roof and shall be cut flush with each surface. Sleeves shall be of such size as to provide a minimum of 6mm all around clearance between bare pipe and sleeve or between jacket over insulation and sleeve. Sleeves shall be of steel pipe or cast iron pipe.
- c) Sleeves in exterior below ground, walls, pits and tanks shall be similar to 'Doyma' sleeves consisting of a galvanised steel sleeve to be embedded in concrete, with the pipe passing through synthetic rubber rings that are compressed using galvanised steel pressure plates on both sides of the rubber ring as shown on drawings.
- d) Equipment and any other component requiring supporting and anchoring shall be provided with properly engineered supports and anchors, as shown on the drawings, or as per manufacturer's recommendation or as directed by the Consultant/Engineer.

4 Valves & Strainers:

a) Automatic Air Vents:

- i) Automatic air vents suitable for liquid systems.
- ii) Body and cover shall be of malleable iron. Float & Valve seat shall be of SS-304.
- iii) Valve head shall be of Vitone (Synthetic Rubber). Connections shall be 13mm or 20mm as specified, screwed BSP. Vents shall be suitable for service up to 125 SWP (8.5bars) & 250°F (120°C) service.

b). Vents shall be similar to model AE 550 manufactured by SPIRAX-SARCO.

C. Air vents shall be provided at high points, on all water coils, and where shown on the drawings to ensure adequate venting of the piping system. A ball valve shall be provided to isolate the vent. The vent outlet shall be piped to a nearby convenient drain using suitable diameter flexible transparent PVC tubing.

d) Expansion Joints:

i) Where indicated on the drawings, expansion joints shall be provided. Expansion joints shall also be provided in all lines subject to temperature changes where indicated or required to relieve strain developed in lines due to temperature increase or decrease.

ii) Pipe alignment guides shall be installed as recommended by the joint manufacturer.

iii). Anchors shall be provided wherever necessary or indicated to localise expansion or to prevent undue strain on piping. Anchors shall consist of heavy steel collars with lugs and bolts for clamping and attaching anchor braces, unless otherwise indicated.

e) Flexible Connectors:

i). Flexible connectors shall be constructed of rubber, tetrafluoroethylene resin, or corrosion resisting steel, bronze, monel or galvanised steel. The material used and the configuration shall be suitable for pressure, vacuum, temperature and circulation medium. The flexible sections may have threaded, welding, soldering, flanged or socket ends and shall be suitable for service intended Flexible connectors shall be designed for 125Psi (8.5 bars) service, and 250°F (120°C).

PART-3: EXECUTION

3.1 Installation Contractor's Responsibilities:

All gate valves, check valves, control valves, butterfly valves, drain cocks, etc. necessary for satisfactory operation of the system shall be provided whether indicated or not. G. All valves whose stem are installed at a height of over 2m from floor level shall be provided with galvanised chain operators. Valves in horizontal lines shall be installed with stem horizontal or vertical above. H. Each valve shall be identified with not less than 35mm round or square black over white laminated plastic tags secured to valve with a suitable brass chain. I. Tags shall be engraved to identify valve by number and valve function

3.2 Installation:

General:

All piping shall be installed in accordance with NFPA standards:

- ◆ NFPA 14 Standard for the installation of Standard-pipe and hose systems.

Pipes shall be cut accurately to measurements established at the job site and worked into place without springing or forcing, properly clearing all windows, doors and other openings. Excessive cutting or other weakening of the building structure to facilitate piping installation will not be permitted without written approval. Layout drawings required under the title of "Approval of Material & Equipment" shall show locations of all supports, the load imposed on each fastening or anchor, typical details for special anchorage, for suspended piping, valves, tank, pumps, converters, and other mechanical equipment. Where supports are required between structural framing members, suitable intermediate metal framing shall be provided and detailed. Pipe shall have burrs removed by reaming and shall be installed to permit free expansion and contraction without damage to joints and hangers. Changes in direction shall be made with fittings, except that bending of pipe 100mm and smaller will be permitted provided a pipe bender is used and wide-sweep bends are formed. The centre line radius of bends shall not be less than 6 diameters of the pipe. Bent pipe showing kinks, wrinkles, flattening or other malformations will not be accepted. All piping shall be installed with sufficient pitch to ensure adequate drainage and venting. Piping connections to equipment shall be provided with unions or flanges. Open ends of pipelines or equipment shall be properly capped or plugged during installation to keep dirt and other foreign matters out of the system.

3.3 PIPE WELDING

A. Production Welding Requirements

1. All production welding including repair welding shall be carried out according to qualified welding procedures and by qualified welders only. The Owner reserves the right, at any time, to make changes in the welding procedure to ensure production of acceptable welds.

2. Scale and slag shall be removed from each weld bead and groove before depositing the next weld bead. Cleaning shall be done by power grinders and wire brushes.

3. Fillet welding shall be done for reinforcing pads, sockets welding fittings and slip-on flanges. Fillet welds shall be continuous, unless otherwise specified in the drawings. Size of fillet welds shall be as indicated on the drawings. Where no size is given, it shall be equal to the thickness of the thinner of the two parts being welded. 4.

Arc burns shall be removed by grinding. Grinding shall have a smooth contour. After grinding, the remaining wall thickness in the area shall not be less than 90% of the nominal wall thickness

4) Welded joints shall be fusion welded by metal arc welding method unless otherwise required. Changes in direction of piping shall be made with welding fittings only. Metering or notching pipe to form elbows & tees or other similar construction will not be permitted. Before welding, the component parts to be welded shall be aligned so that no strain is placed on the weld when finally positioned. Height shall be so aligned that no part of the pipe wall is offset by more than 20% of the wall thickness. Flanges and branches shall be set true. This alignment shall be preserved during the welding operation. Removing and replacing defective welds shall be at no additional cost to the Owner. Repairing of defective welds by adding new material over the defects or by peeling will not be permitted. Electrodes shall be stored in a dry heated area and shall be kept free of moisture or dampness during fabrication operations. Electrodes that have lost part of their coating shall be discarded.

Inspection and Testing:

A. Hydrostatic Testing:

The piping shall be tested with water and all welds carefully inspected for leaks. The pressure shall be raised slowly and steadily until test pressure is reached. The pressure shall be maintained while a thorough examination is made to ensure that all welding are sound and show no leaks or undue distortion.

B. Repairs & Welds: Defective welds found during pressure test shall be cut out for a distance of not less than 25mm on either side of the defect and shall be rewelded.

C. Repeat Pressure Test: Following the execution of any repairs found to be necessary, the piping shall again be tested in accordance with the above specs.

3.3 Pipe Supports:

All supports and anchors shall be installed in accordance with NFPA Standard.

3.4 Pressure Testing: A. Fire Protection piping shall be hydrostatically tested at a pressure equal to 150% of the maximum operating pressure, but not less than 200psi (13.6 bars), for a period of time sufficient to inspect every joint in the system but in no case less than two hours. No loss of pressure will be allowed. Leaks found during tests shall be repaired by re-welding or replacing pipe or fittings. Caulking of joints will not be permitted. Concealed piping shall be tested in place before concealing. Tests shall be conducted in the presence of the Consultant or the Consultant's representative who shall be given 10 days notice before any test is to be conducted. All material, equipment or instruments required for tests shall be provided by the Contractor.

MS Fire Pipe Painting Procedure & Specifications

1. Scope

This specification covers the painting of mild steel fire protection pipes to prevent corrosion and provide fire safety identification as per applicable codes.

2. Materials

Primer: Red oxide zinc chromate or epoxy primer suitable for steel

Topcoat: Fire protection red paint (usually synthetic enamel or epoxy-based)

Cleaning agents: Solvents for degreasing (e.g., mineral spirits)

3. Surface Preparation

Remove all oil, grease, dirt, rust, mill scale, and other contaminants.

Recommended method:

Wire brushing or power tool cleaning for small areas, but blasting is preferred.

After cleaning, the surface should be dry and free from dust and loose particles.

4. Painting Procedure

Step 1: Cleaning

Wipe the pipe surface with approved solvent to remove any grease or oil.

Step 2: Primer Application

Apply one coat of red oxide zinc chromate primer immediately after surface preparation.

Ensure primer thickness is approx. 25-35 microns (1-1.5 mils) dry film thickness (DFT).

Allow primer to dry as per manufacturer's instructions (usually 2-4 hours).

Step 3: Topcoat Application

Apply two coats of fire protection red synthetic enamel or epoxy topcoat over the primer.

Each coat should have a dry film thickness of approx. 25-30 microns (1-1.2 mils).

Total dry film thickness (primer + topcoats) should be approx. 75-90 microns (3-3.5 mils).

Allow each coat to dry fully before applying the next coat.

5. Color Coding

Fire sprinkler and fire protection pipes must be painted bright red to comply with NFPA and local fire codes.

If required, apply stenciled identification markings or labels as per project specifications.

6. Inspection & Quality Control

Check surface cleanliness (visually and/or with a test patch).

Measure dry film thickness using a gauge to ensure compliance.

Adhesion test may be performed per ASTM D3359 (Tape Test).

Ensure paint coverage is uniform, smooth, and without runs or sagging.

7. Safety & Environmental Considerations

Use paint and solvents in well-ventilated areas.

Provide personal protective equipment (PPE) such as masks, gloves, and eye protection.

Pipe Measurement

Measurements of plumbing work shall be on following basis:-

a) Piping shall be measured along the centre line of installed pipes including all pipe fittings and accessories but excluding valves and other items for which quantities are specifically indicated in the schedule of work. No separate payment shall be made for fittings and accessories.

b) The rate for piping work shall include all wastage allowances, flanges pipe supports, hangers, excavation, refilling, testing, nuts, vibration isolators, and suspension where specified or required, and any other item required to complete the piping installation. None of these items will be separately measured and paid.

CHAPTER -3 VALVES & ACCESSORIES

a) Sluice Valves

Sluice valve conforming to UL: 262 shall be provided. Valves shall be suitable to withstand the pressure in the system and rating shall be PN 20. Valves shall be right-handed (i.e. handle or key shall be rotated clock wise to close the valve), the direction of opening and closing shall be marked and an open/shunt indicator fitted. The material of valves shall be as under:

Body : Cast iron

Disc: Stainless steel

Seat: Nitrile rubber

O-ring: Nitrile

b) Butterfly Valves with and without Tamper Proof Switch

Butterfly valve conforming to UL: 1091 shall be provided. Butterfly valve shall be suitable to withstand the pressure in the system and rating shall be PN 20. Valves shall be right-handed (i.e. handle or key shall be rotated clock wise to close the valve),

the direction of opening and closing shall be marked and an open/shunt indicator fitted. The material of valves shall be as under:

Body: Cast iron

Disc: Stainless steel

Seat: Nitrile rubber

O-ring: Nitrile

Tamper Proof Switch has 100 percent synchronization which activates the alarm panel even when the valve is closed upto 50% and in bidirectional way. In addition, the switch is designed to operate in temperatures ranging from -40°C to 49°C (-40°F to 120°F). The Switch is equipped with tamper resistant cover screws to prevent unauthorized entry. Inside, two sets of SPDT (Form C) synchronized switches are enclosed in a durable terminal block to assure reliable performance.

C) Non-Return Valve

Non-return valves shall be swing check type in horizontal run and lift check type in vertical run of pipes. They shall conform to UL 312. They shall be suitable to with-stand the pressure in the system and rating shall be PN 20. The material of valves shall be as under:

Body: Cast iron

Disc: Stainless steel

Seat: Nitrile rubber

O-ring: Nitrile

d) AIR RELEASE VALVE

Air release valves shall be provided at all high points in the piping system for venting. Valves shall be of the double float type, with G.M. body, vulcanite balls, rubber sealing, etc. Air valves shall be of the sizes specified and shall be associated with an equal size forged ball valve.

e) Full Way Ball Valve

The Ball Valve shall be made from forged brass. The valve shall be internally threaded to receive pipe connections.

The Ball shall be made from brass and machined to perfect round shape and subsequently chrome plated. The seat of the valve body bonnet gasket and gland packing shall be of Teflon. The handle shall be of chrome plated steel with PVC jacket. The handle shall also indicate the direction of 'open' and 'closed' situations. The gap between the ball and the teflon packing shall be sealed to prevent water seeping. The

handle shall also be provided with a lug to keep the movement of the ball valve within 90 degree.

f) Hydrant Valves

- A. Ø 65mm (2.5 inch)
 - 1. Manufacturer: Refer List of Approved Manufacturers.
 - 2. Standard: BS 5041 ; UL 668
 - 3. Body: Copper Alloy to BS 1400
 - 4. Pressure rating: 250 psig
 - 5. Connections: threaded or flanges as required.
 - 6. Configuration: Straight, right angled, oblique or bib nose as required, indicated on drawings or directed by Consultant.

Hydrant Valves with Pressure Regulating Valve

- A. Ø 65mm (2.5 inch)
 - 1. Manufacturer: Refer List of Approved Manufacturers.
 - 2. Standard: BS 5041 ; UL 668
 - 3. Body: Copper Alloy to BS 1400 and provided with a PRV to control outlet static pressure from 5 to 8 bars with inlet pressure up to 300 psig.
 - 4. Pressure rating: 300 psig
 - 5. Connections: threaded or flanges as required.

Configuration: Straight, right angled, oblique or bib nose as required, indicated on drawings or directed by Consultant

g) Fire-Department Connections

- A. Manufacturer: Refer List of Approved Manufacturers.
- B. Standard: UL 405.
- C. Design: Exposed Type- projecting for wall mounting; or Flush type for wall mounting, as indicated on drawings or DATA SHEET.
- D. Pressure Rating: 175 psig minimum.
- E. Body Material: Corrosion-resistant metal.
- F. Inlets: Brass with threads according to NFPA 1963 and matching local fire-department sizes and threads. Include extension pipe nipples, brass lugged swivel connections, and check devices or clappers.
- G. Number of Inlets: Two X 65mm dia.
- H. Caps: Brass, lugged type, with gasket and chain.
- I. Escutcheon Plate: Round for projecting type and rectangular for flush mounting type; brass, wall type.
- J. Escutcheon Plate: Marking: Similar to "AUTO SPKR & STANDPIPE" . Finish: Polished chrome plated
- K. Outlet: Back, with pipe threads; 100mm

h) Strainer

Strainers shall be preferably of the approved type with fabricated steel bodies. Strainers shall be fabricated by minimum 1 mm thick stainless-steel sheet with 3 mm dia. perforation holes. Strainers shall be provided with flanges or threaded sockets as required. They shall be designed so as to enable blowing out accumulated dirt and facilitate removal and replacement of screen without disconnection of the main pipe.

i) Pressure Gauges

Pressure gauges shall be of 150mm dia. dial and of appropriate range and be complete with shut off gauge valve etc. duly calibrated before installation. Care shall be taken to protect pressure gauges during pressure testing.

j) Flexible Connection For Pumps

All suction and delivery lines shall be provided with double flanged reinforced neoprene flexible pipe connectors. Connectors should be suitable for a working pressure of each pump. Length of the connector shall be as per manufacturer's details.

Installation Contractor's Responsibilities:

- A. All gate valves, check valves, control valves, butterfly valves, drain cocks, etc. necessary for satisfactory operation of the system shall be provided whether indicated or not.
- B. All valves whose stem are installed at a height of over 2m from floor level shall be provided with galvanised chain operators. Valves in horizontal lines shall be installed with stem horizontal or vertical above.
- C. Each valve shall be identified with not less than 35mm round or square black over white laminated plastic tags secured to valve with a suitable brass chain.

Fire Booster Flow Diagram in NFPA 20

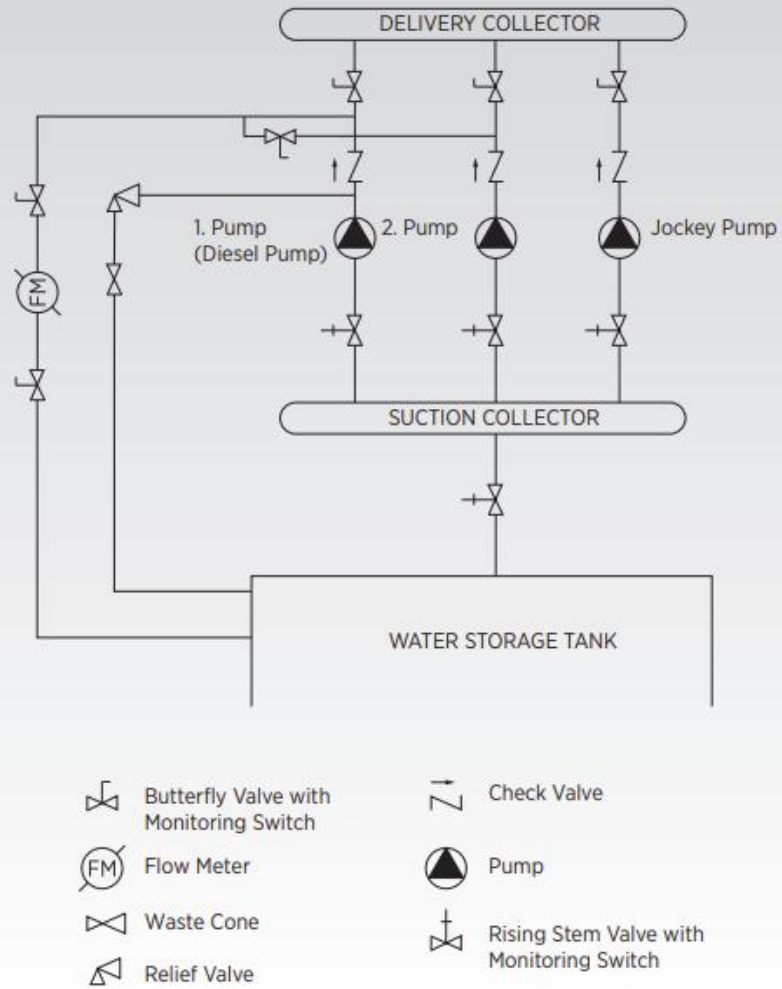
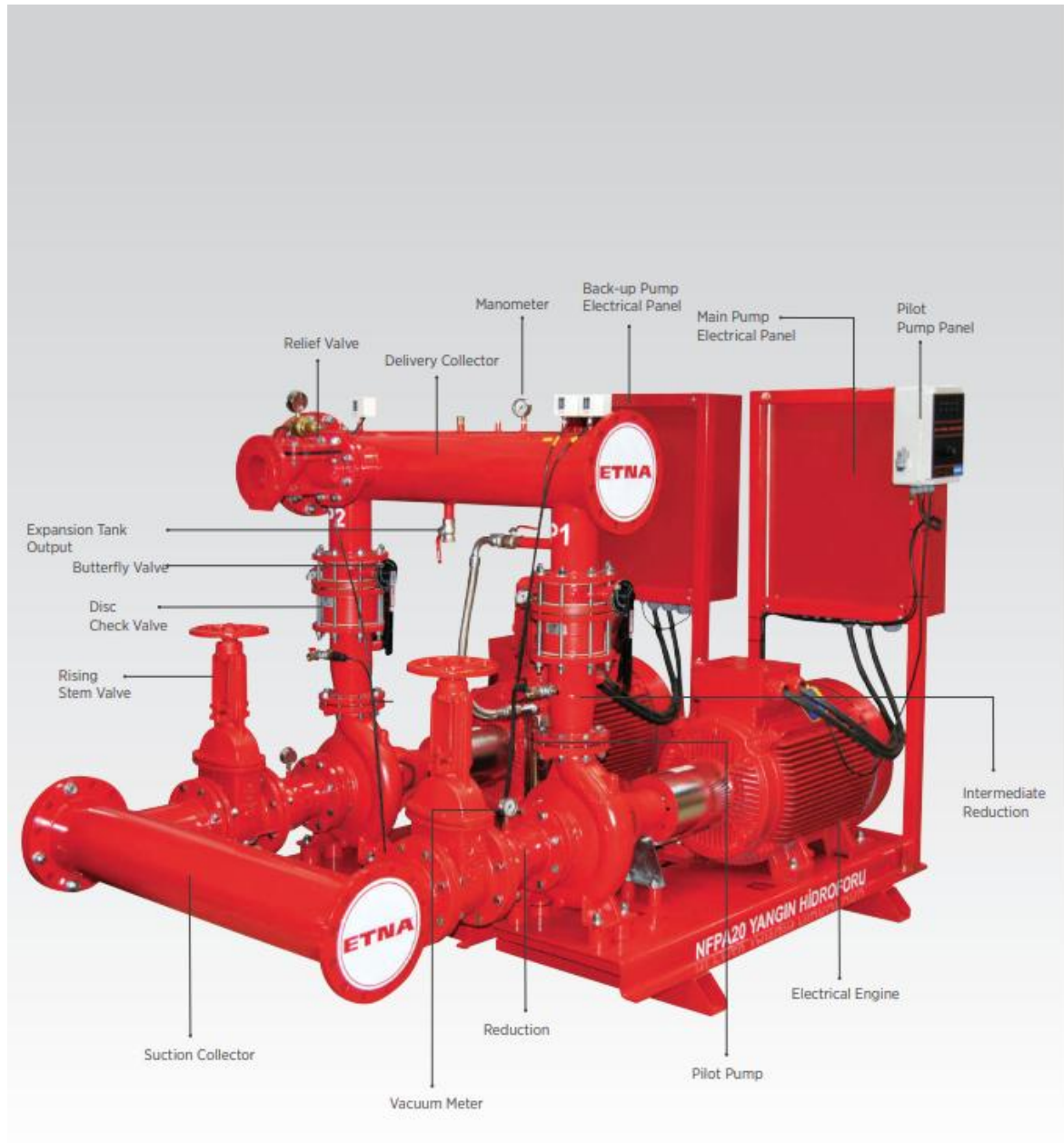

Figure 5: Fire Booster Flow Diagram in NFPA 20



CHAPTER -4 RCC FIRE PUMP ROOM

- Fire pumps must be installed in a dry, accessible, ventilated pump room
- They may be installed below the water tank level to achieve flooded suction

- But **the pump room must remain dry and above flood levels**

Recommended suction arrangement

Flooded suction from tank

- Suction pipe slope upward toward tank
- Suction pipe size $\geq 1.25 \times$ **pump suction diameter**
- Straight pipe length before pump $\geq 10 \times$ **pipe diameter**

NFPA 20 required clearances

NFPA 20 requires:

- **Minimum 900 mm (3 ft)** clear working space **around all sides** of:
 - Fire pump
 - Pump motor
 - Controllers
- **Minimum 1,100 mm (42 in)** in front of electrical controllers
- Clear access to valves, gauges, and maintenance points

500 GPM electric pump + jockey + panels, a realistic minimum is

9'-0" X 10'-0" height min 10'-0" with proper ventilation and fire rated exit door.

CHAPTER -5 FIRE HOSE REEL & RACKS

PART-1: GENERAL

Section Scope:

The contractor shall supply hose reel and racks of the required specs as given in the EQUIPMENT DATA SHEET.

Submittals:

Tendering Stage Submittal

The tenderer shall indicate the equipment he intends to use and shall provide their source.

Construction Stage Submittal

The contractor shall provide complete details of all equipment to be used, and shall obtain Consultants approval.

Quality Assurance:

Factory Test:

Each equipment shall undergo a series of standard factory tests to ensure that the unit is leak tight, and that every aspect of unit fabrication meets stringent quality standards in accordance with good practice and the manufacturer's quality assurance requirements.

1.1 Delivery, Storage, and Handling:

Hoses and Racks shall be stored and handled in accordance with the manufacturer's recommendations.

Equipment shall be shipped with nameplates indicating name of manufacturer, model size, serial number, and all other data.

Warranty:

Manufacturer shall guarantee the equipment and components against defects in materials and/or workmanship for a period of one year from date of initial operation or 18 months from date of shipment, whichever occurs first, unless otherwise stated elsewhere in this document.

PART-2: PRODUCTS

Fire Hose Reel:

The Contractor shall supply and install recessed, swinging arm type, Fire Hose Reels, where indicated on the drawing. The Hose Reels shall conform to BS 5274:1985 and shall consist of:

Hose Reel Lock Shield Valve: manufactured from materials resistant to de-zincification, Ø25mm, threaded.

Side Disks: 18SWG, galvanised steel sheets, powder coated, post office red color.

Hose: Red rubber smooth, covered to BS3169 Type 1, Class B; Ø25mm and 30.5m long.

Control Nozzle: Nylon lever operated jet/spray

2.1 Fire Hose Reel Cabinet:

Provide and install Fire Hose Reel Cabinet constructed from 16SWG galvanised sheet steel, powder coated to BS18 B25. Cabinet shall be minimum of size 850mm x 850mm and shall be minimum 350mm deep.

Water Entry: Top, bottom, back or side, 50 dia knockouts to suit pipework requirements.

Architrave: 20SWG stainless steel, brushed satin finish.

Door: 15mm MDF finished in pre-catalysed lacquer both sides and edges in BS06 C33.

Concealed Hinges: Concealed hinges, left or right as required.

Name Panel/Finger Pull: Recessed stainless steel, brushed satin finish. Caption "FIRE HOSE REEL" in red 45mm high. Universal logo showing fire hose reel shall also be provided.

Instruction on reverse of panel: "IN CASE OF FIRE PULL HOSE FROM REEL AND WATER WILL TURN ON AUTOMATICALLY".

2.2 Fire Hose Reel Cabinet Door:

- A. **Where steel cabinet is not felt necessary, only the Door will be installed over a recesses in the masonry construction for the hose reel, and / or extinguishers, as shown in the detail drawings.**
- B. **Separate doors, one on top of another shall be provided & installed. The top door shall be for the hose reel, while the bottom door shall be to house fire extinguishers, as shown in the detail drawings.**
- C. **Doors shall conform to specifications given at Clause 2.2 above for Hose Reel Cabinet.**

2.3 Fire Hose Rack:

- A. **The Contractor shall supply and install fire-hose rack with hose of diameter 40mm with instantaneous coupling terminated with light alloy jet / spray nozzle.**
- B. **Hose shall attaché to Ø 65mm fire hydrant valve (angle valve). Length of hose shall be 30 meter. Hose shall comply with British Standards BS-3169.**
- C. **Fire hose shall be rubber lined with nylon hose.**
- D. **Hose shall be as approved by the Consultant.**

2.4 Hose Rack Cabinet:

- A. **Provide and install fire hose rack cabinet constructed from 16SWG galvanised steel sheet, powder coated to fire red colour according to BS 18 B 25. Cabinet shall have a minimum size of 600mm wide x 800mm high x 150mm deep, and shall have a full glass door.**

2.5 Orifice Plates:

- A. **Where the dynamic pressure at the inlet to Fire Hose Reel exceeds 2.75 bars (40 psi) an orifice plate shall be installed prior to the inlet of Fire Hose Reel.**
- B. **The orifice plate shall be fabricated of 6mm thick stainless steel (SS 304) and installed between steel flanges. Size of the bore shall be determined by the contractor.**
- C. **Shop drawing shall be submitted to the Consultant for approval prior to the fabrication.**

PART-3: EXECUTION

- D. The equipment shall be installed where shown on drawings & shall be installed as per the manufacturer recommendations.

CHAPTER-6 FIRE HYDRANT & STAND PIPES

PART-1: GENERAL

1.1 Scope of Work:

The work under this section of the specifications consists of providing all material and labour for proper installation of fire hydrants and stand pipes.

1.2 Submittals:

Tendering Stage Submittal

The tenderer shall indicate the fire hydrants and stand pipes he intends to use and shall provide their source.

Construction Stage Submittal

The contractor shall provide complete details of fire hydrants and stand pipes to be used, and shall obtain Consultants approval.

Warranty:

Manufacturer shall guarantee the equipment and components against defects in materials and/or workmanship for a period of one year from date of initial operation or 18 months from date of shipment, whichever occurs first, unless otherwise stated elsewhere in this document.

PART-2: PRODUCTS

2.1 Dry Barrel –Pillar Hydrant – Double Headed:

- A. Fire Stand Pipes shall be of Pillar Hydrant type, of size dia 150mm, tested to 250 psi. The pillar Hydrant shall be constructed of steel, and shall consist of four sections, i.e. Dry Port, Upper Barrel, Lower Barrel, and Inlet Connection. The Dry Port shall be O’Ring sealed. The Upper Barrel shall be bolted on top to the Dry Port and at the Bottom to the Lower Barrel. The Upper Barrel shall house the outlet consisting of two nos. Ø 65mm hydrant valves with instantaneous couplings. The Lower Barrel shall carry the main hydrant valve, which shall be constructed of cast-iron and shall have a conical shaped synthetic rubber moulded disc which shall seat on to a precision machined bronze seat. The main hydrant valve shall be compression type opening against the pressure and closing with it, and shall be actuated by a cast bronze nut which shall rotate the steel hydrant rod.

2.2 Double Delivery Standpipe:

- A. Shall be manufactured using Ø 6inch Schedule 40, Black steel pipe, fully welded, conforming to dimensions given in detail drawing, approximately 36 inch high, and with the top end capped. The barrel will be provided at the top with two dia 2½ “ hydrant valves, placed 180° apart, and each outlet shall be provided with an instantaneous coupling. The bottom of the standpipe shall be flanged.

PART-3: EXECUTION

3.1 Installation:

- A. Dry Barrel –Pillar Hydrant – Double Headed
 1. Hydrant valve shall be provided with flanged inlet and tee-base. All nuts and bolts shall be zinc passivated and plated. Hydrant barrel shall be painted inside and out with a primer, and finish painted on sections below ground level with black bituminous paint, while exposed surfaces shall have red high glass enamel.
- B. Double Delivery Standpipe
 1. When installing the standpipe, the piping leading to the standpipe shall be provided with concrete foundation/thrust block as shown in detail drawing.

DRAWINGS

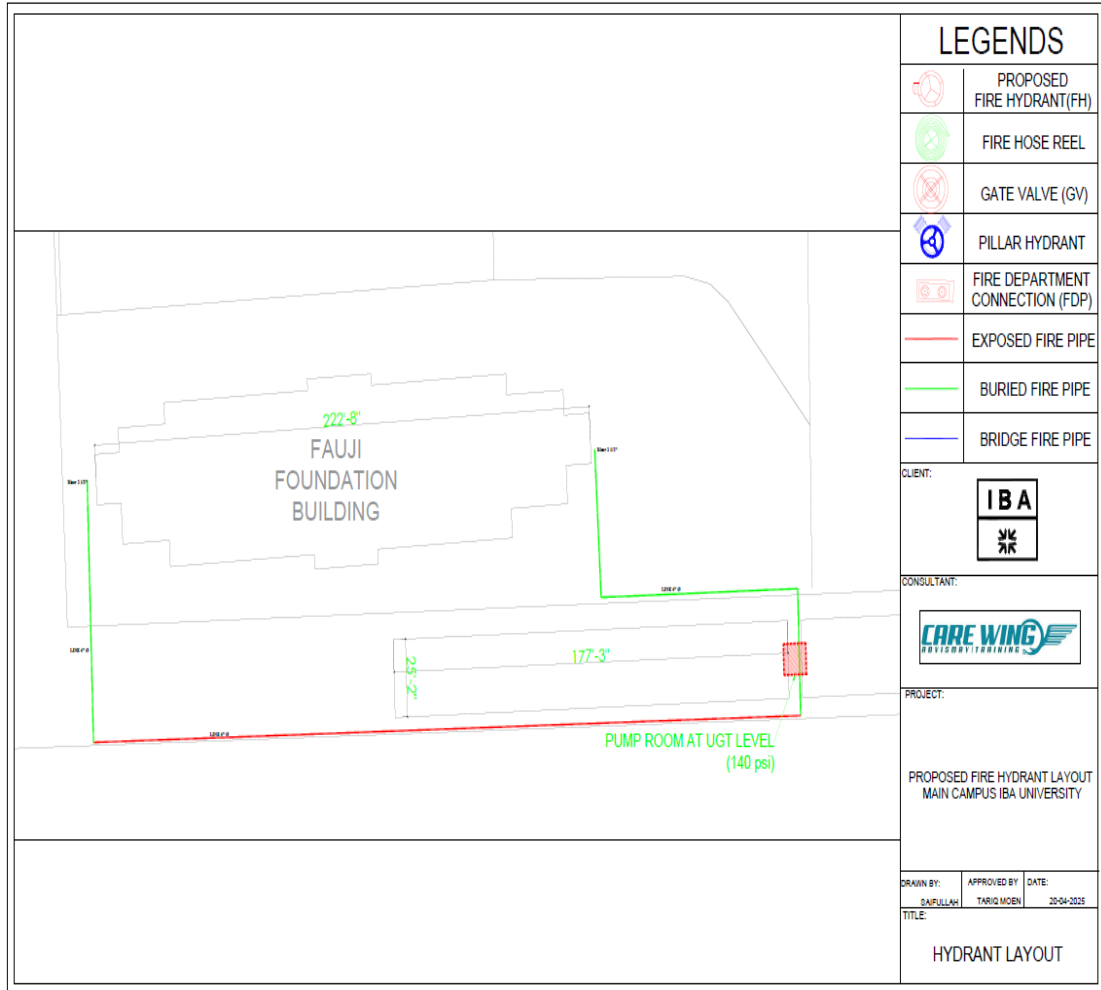

LEGENDS

| | |
|--|----------------------------------|
| | PROPOSED FIRE HYDRANT (FH) |
| | FIRE HOSE REEL |
| | GATE VALVE (GV) |
| | PILLAR HYDRANT |
| | FIRE DEPARTMENT CONNECTION (FDP) |
| | EXPOSED FIRE PIPE |
| | BURIED FIRE PIPE |
| | BRIDGE FIRE PIPE |

CLIENT:

CONSULTANT:

PROJECT:
 PROPOSED FIRE HYDRANT LAYOUT
 MAIN CAMPUS IBA UNIVERSITY

| | | |
|------------------------|----------------------------|---------------------|
| DRAWN BY: SARFULLAH | APPROVED BY: TARIQ MOEN | DATE: 20-04-2025 |
|------------------------|----------------------------|---------------------|

TITLE:
 HYDRANT LAYOUT

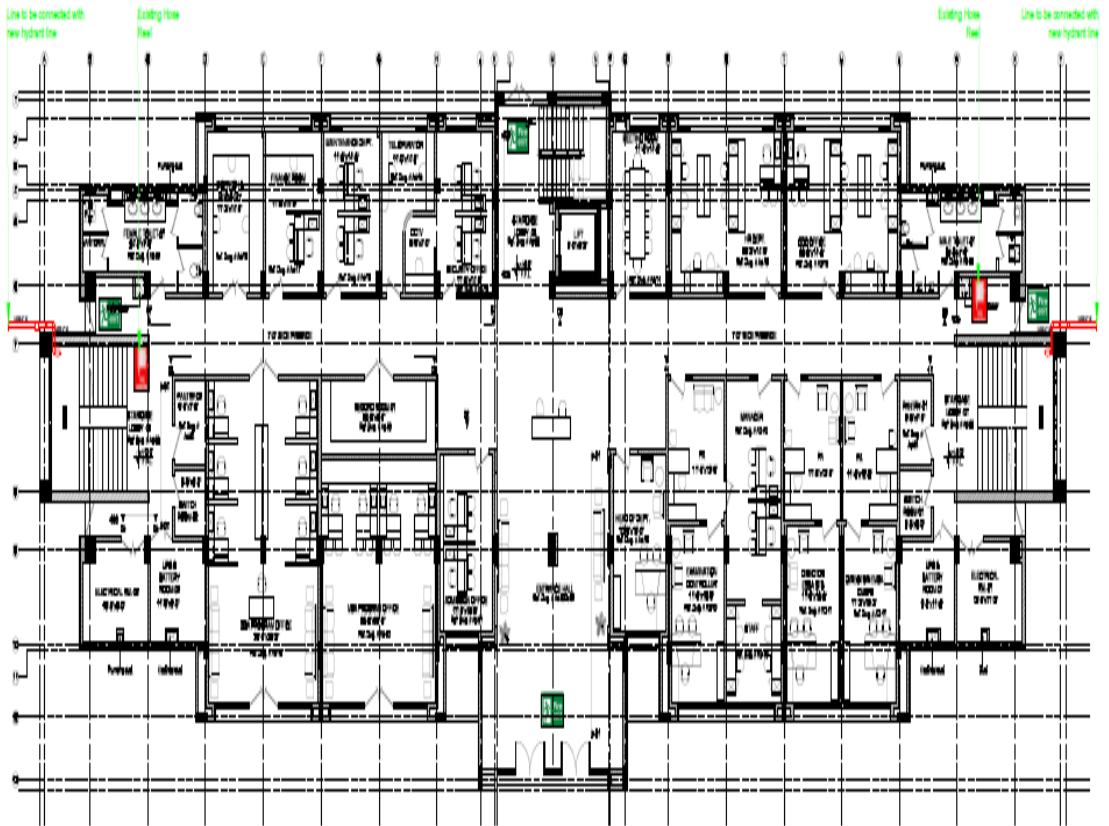

GROUND FLOOR

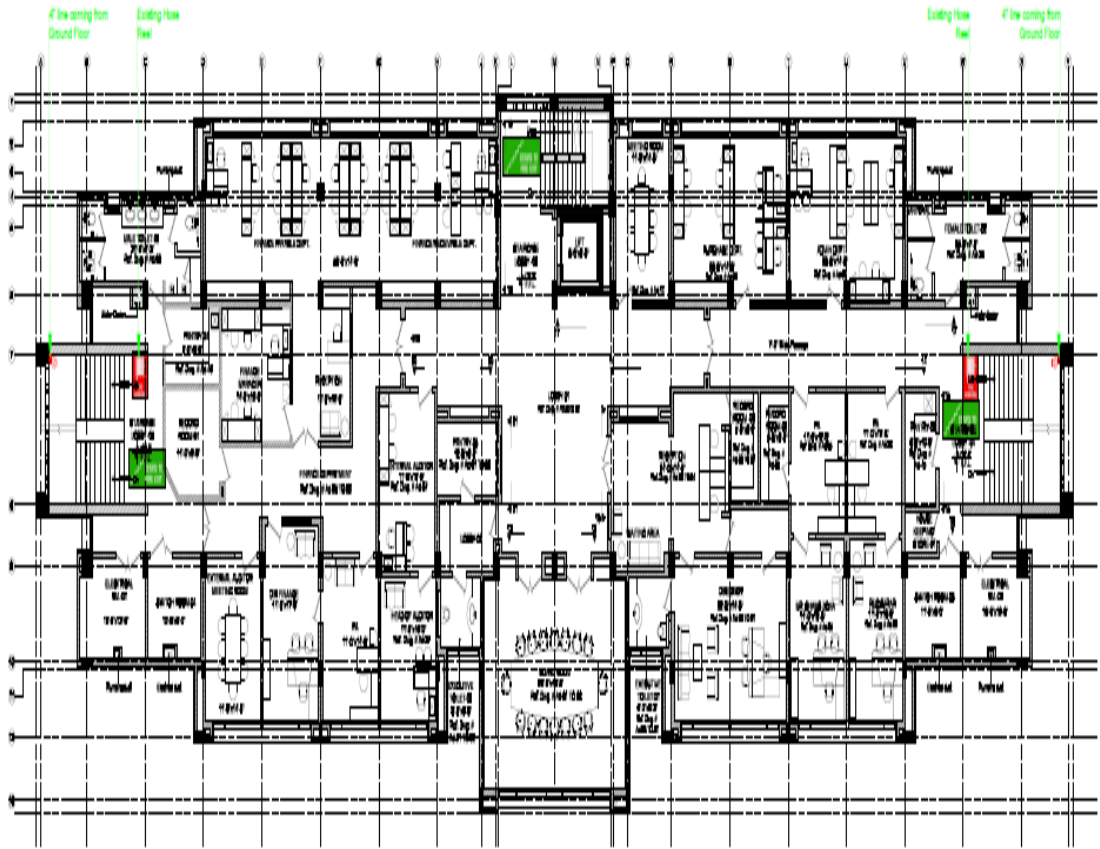

FIRST FLOOR

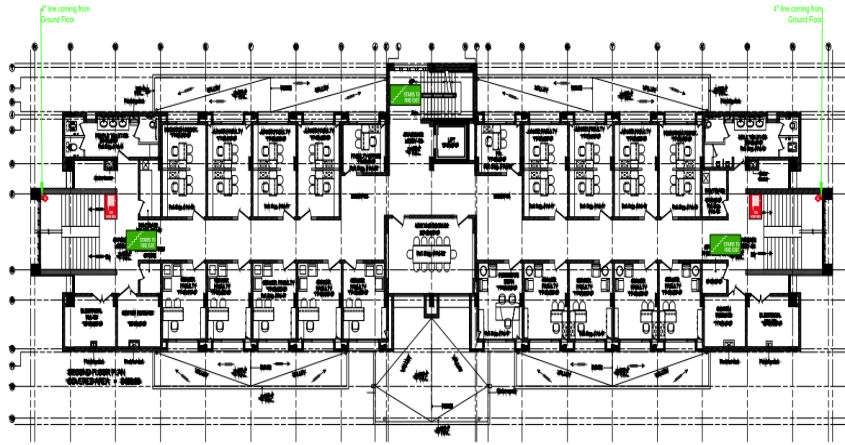

SECOND FLOOR



CLIENT:



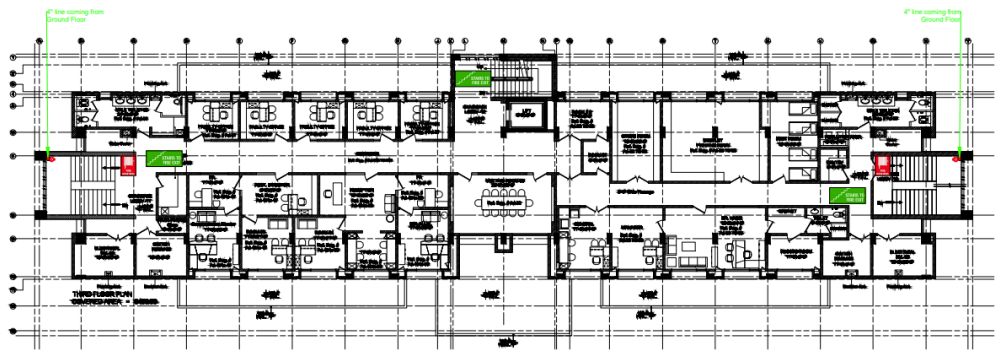

THIRD FLOOR



FORMS

FORM OF BID SECURITY (Bank Guarantee)

Security Executed on _____
(Date)

Name of Surety (Bank) with Address:
(Scheduled Bank in Pakistan)

Name of Principal (Bidder) with Address: _____

Security Amount in Rupees. _____ (Rs. _____)

Bid Reference No. _____

KNOW ALL MEN BY THESE PRESENTS, that in pursuance of the terms of the Bid and at the request of the said Principal (Bidder) we, the Surety above named, are held and firmly bound unto _____ (hereinafter called the 'Employer') in the sum stated above for the payment of which sum well and truly to be made, we bind ourselves, our heirs, executors, administrators and successors, jointly and severally, firmly by these presents.

THE CONDITION OF THIS OBLIGATION IS SUCH, that whereas the Bidder has submitted the accompanying Bid dated _____ for Bid No. _____ for _____ (Particulars of Bid) to the said Employer; and

WHEREAS, the Employer has required as a condition for considering said Bid that the Bidder furnishes a Bid Security in the above said sum from a Scheduled Bank in Pakistan, to the Employer, conditioned as under:

- (1) that the Bid Security shall remain in force up to and including the date 30 days after the deadline for validity of bids as stated in the Instructions to Bidders or as it may be extended by the Employer, notice of which extension(s) to the Surety is hereby waived;
- (2) that the Bid Security of unsuccessful Bidders will be returned by the Employer after expiry of its validity or upon signing of the Contract Agreement; and
- (3) that in the event of failure of the successful Bidder to execute the proposed Contract Agreement for such work and furnish the required Performance Security, the entire said sum be paid immediately to the said Employer pursuant to Clause 15.6 of the Instruction to Bidders for the successful Bidder's failure to perform.

NOW THEREFORE, if the successful Bidder shall, within the period specified therefor, on the prescribed form presented to him for signature enter into a Contract Agreement with the said Employer in accordance with his Bid as accepted and furnish within seven (07) working days of issuance of Letter of Acceptance, a Performance Security with good and sufficient surety, as may be required, upon the form prescribed by the said Employer for the faithful performance and proper fulfilment of the said Contract Agreement or in the event of non-withdrawal of the said Bid within the time Form of Bid Security

specified for its validity then this obligation shall be void and of no effect, but otherwise to remain in full force and effect.

PROVIDED THAT the Surety shall forthwith pay the Employer the said sum upon first written demand of the Employer (without cavil or argument) and without requiring the Employer to prove or to show grounds or reasons for such demand, notice of which shall be sent by the Employer by registered post duly addressed to the Surety at its address given above.

PROVIDED ALSO THAT the Employer shall be the sole and final judge for deciding whether the Principal (Bidder) has duly performed his obligations to sign the Contract Agreement and to furnish the requisite Performance Security within the time stated above, or has defaulted in fulfilling said requirements and the Surety shall pay without objection the said sum upon demand authority of its governing body.

SURETY (Bank)

WITNESS: _____ Signature
from the Employer forthwith and without any reference to the Principal (Bidder) or any other person.

IN WITNESS WHEREOF, the above bounden Surety has executed this Guarantee under its seal on the date indicated above, the name and seal of the Surety being hereto affixed and these presents duly signed by its undersigned representative _____ pursuant to

1. _____ Name _____

Title

Corporate Secretary (Seal)

Corporate Guarantor (Seal)

2. _____

Name, Title & Address

**FORM OF PERFORMANCE SECURITY
(Bank Guarantee)**

Guarantee No. _____
Executed on _____
Expiry date _____

[Letter by the Guarantor to the Employer]

Name of Guarantor (Bank) with address:

(Scheduled Bank in Pakistan)

Name of Principal (Contractor) with address:

Security Amount (express in words and figures) _____

Letter of Acceptance No. _____ Dated _____

KNOW ALL MEN BY THESE PRESENTS, that in pursuance of the terms of the Bidding Documents and above said Letter of Acceptance (hereinafter called the Documents) and at the request of the said Principal we, the Guarantor above named, are held and firmly and irrevocably and _____ unconditionally bound unto _____ the _____ (hereinafter called the Employer) in the sum of the amount stated above for the payment of which sum well and truly to be made to the said Employer, we bind ourselves, our heirs, executors, administrators and successors, jointly and severally, firmly by these presents.

THE CONDITION OF THIS OBLIGATION IS SUCH, that whereas the Principal has accepted the Employer's above said Letter of Acceptance for _____ (Name of Contract) for the _____ (Name of Project).

NOW THEREFORE, if the Principal (Contractor) shall well and truly perform and fulfill all the undertakings, covenants, terms and conditions of the said Documents during the original terms of the said Documents and any extensions thereof that may be granted by the Employer, with or without notice to the Guarantor, which notice is, hereby, waived and shall also well and truly perform and fulfill all the undertakings, covenants terms and conditions of the Contract Agreement and of any and all modifications of said Documents that may hereafter be made, notice of which modifications to the Guarantor being hereby waived, then, this obligation to be void; otherwise to remain in full force and virtue till all requirements of Clause 8.3, Defects Liability, of Conditions of Contract are fulfilled.

Our total liability under this Guarantee is limited to the sum stated above and it is a condition of any liability attaching to us under this Guarantee that the claim for payment in writing shall be received by us within the validity period of this Guarantee, failing which we shall be discharged of our liability, if any, under this Guarantee.

Form of Performance Security

We, _____ (the Guarantor), waiving all objections and defences under the Contract, do hereby irrevocably and independently guarantee to pay to the Employer without delay upon the Employer's first written demand without cavil or arguments and without requiring the Employer to prove or to show grounds or reasons for such demand any sum or sums up to the amount stated above, against the Employer's written declaration that the Principal has refused or failed to perform the obligations under the Contract Agreement which payment will be effected by the Guarantor to Employer's designated Bank & Account Number.

PROVIDED ALSO THAT the Employer shall be the sole and final judge for deciding whether the Principal (Contractor) has duly performed his obligations under the Contract Agreement or has defaulted in fulfilling said obligations and the Guarantor shall pay without objection any sum or sums up to the amount stated above upon first written demand from the Employer forthwith and without any reference to the Principal or any other person.

IN WITNESS WHEREOF, the above-bounden Guarantor has executed this Guarantee under its seal on the date indicated above, the name and corporate seal of the Guarantor being hereto affixed and these presents duly signed by its undersigned representative, pursuant to authority of its governing body.

Guarantor (Bank)

Witness:
1. _____

Signature _____

Corporate Secretary (Seal)

Name _____

Title _____

2. _____

Name, Title & Address

Corporate Guarantor (Seal)

**FORM OF MOBILIZATION ADVANCE PAYMENT
(Bank Guarantee)**

Guarantee No. _____ Date _____
WHEREAS _____ (hereinafter called the 'Employer') has entered into a Contract for

(Particulars of Contract) with _____ (hereinafter called the
"Contractor").

AND WHEREAS, the Employer has agreed to advance to the Contractor, at the Contractor's request, an amount of Rupees _____ (Rs _____) which amount shall be advanced to the Contractor as per provisions of the Contract.

AND WHEREAS, the Employer has asked the Contractor to furnish Guarantee to secure the advance for the performance of his obligations under the said Contract.

AND WHEREAS, _____
(Scheduled Bank in Pakistan) (hereinafter called the "Guarantor") at the request of the Contractor and in consideration of the Employer agreeing to make the above advance to the Contractor, has agreed to furnish the said Guarantee.

NOW, THEREFORE, the Guarantor hereby guarantees that the Contractor shall use the advance for the purpose of above-mentioned Contract and if he fails and commits default in fulfilment of any of his obligations for which the advance payment is made, the Guarantor shall be liable to the Employer for payment not exceeding the aforementioned amount. Notice in writing of any default, of which the Employer shall be the sole and final judge, on the part of the Contractor, shall be given by the Employer to the Guarantor, and on such first written demand, payment shall be made by the Guarantor of all sums then due under this Guarantee without any reference to the Contractor and without any objection. This Guarantee shall remain in force until the Delivery of Machinery, Equipment and Material of the System at Site upon verification and confirmation of the Employer. The Guarantor's liability under this Guarantee shall not in any case exceed the sum of Rupees _____ (Rs _____). This Guarantee shall remain valid up to seven (07) days of the aforesaid confirmation letter by the Employer and shall be null and void after the aforesaid date.

GUARANTOR

Signature _____
Name / Title _____

WITNESS

1. _____
Corporate Secretary (Seal)
2. _____
(Name Title & Address)

Guarantor (Seal) Corporate

Form of Advance Payment Guarantee

INDENTURE FOR SECURED ADVANCES.

(For use in cases in which is contract is for finished work and the contractor has entered into an agreement for the execution of a certain specified quantity of work in a given time).

This INDENTURE made the day of
----- -197--" BETWEEN (hereinafter called "the Contractor" which expression shall where the context so admits or implied be deemed to include his heirs, executors, administrators and assigns) of the one part and THE GOVERNOR OF SINDH (hereinafter called "the Government" of the other part).

WHEREAS by an agreement, dated (hereinafter called the said agreement, the contractor has agreed to perform the under-mentioned works (hereinafter referred to as the said work):-

(Here enter (the description of the works).1

AND WHEREAS the contractor has applied to the
— for an advance to him of Rupees (Rs.) on the security of materials absolutely belonging to him and brought by him to the site of the said works the subject of the said agreement for use in the construction of such of the said works as he has undertaken to execute at rates fixed for the finished work (inclusive of the cost of materials and labour and other charge) AND WHEREAS the Government has agreed to advance to the Contractor the sum of Rupees, (Rs.) on the security of materials the quantities and other particulars of which are detailed in Running Account Bill the said works signed by the contractor on----- — and on such covenants and conditions as are hereinafter contained and the Employer has reserved to itself the option of marking any further advance or advances on the security of other materials brought by the Contractor to the site of the said works.

NOW THIS INDENTURE WTTNESSETH that in pursuance of the said agreement and in consideration of the sum of Rupees -
(Rs. -----) on or before the execution of these presents paid to the Contractor by the Government (the receipt whereof the Contractor doth hereby acknowledge) and of such further advances (if any) as may be made to him as aforesaid (all of which advances are hereinafter collectively referred to as the said amount) the Contractor doth hereby assign unto the Government the said materials by way of security for the said amount follow :-

And doth hereby covenant and agree with the Government and declare ay

(1) That the said sum of Rupees- (RF. -----) so advanced by the Employer to the Contractor as aforesaid and all or any further sum or sums which may be advanced aforesaid shall be employed by the contractor in or towards expending the execution of the said works and for no other purpose whatsoever.

Offered to and accepted by the Employer as security for the said amount are absolutely by the Contractors own property free from encumbrances of any kind and the Contractor will not make any application for or receive a further advance on the security of materials which are not absolutely his own property and free from encumbrances of any kind and the contractor hereby agrees, at all times, to indemnify and save harmless the Government against all claims whatsoever to any materials in respect of which an advance has been made to him as aforesaid.

(3) That the said materials detailed in the said Running Account Bill (B) and all other Fin. R. Form No. 17-A

Materials on the security of which any further advance or advances may hereafter be made as aforesaid (hereinafter called the said materials) shall be used by the Contractor solely in *the* execution of the said works in accordance with the directions of the Engineer in Charge and in the terms of the said agreement.

(4) That the Contractor shall make at his own cost all necessary and adequate arrangement for the proper watch, safe custody and protection against all risks of the said material and that until used in construction as aforesaid the said materials shall remain at the site of the said works in the Contractor's custody and at his own risk and on his own responsibility and shall at

all times be open to inspection by Engineer in charge or any officer authorized by him. In the event of the said materials of any part (hereof being stolen, destroyed or damaged or becoming deteriorated in a grater degree than is due to reasonable use and wear thereof Contractor will forthwith replace the same with other materials of like qualify or repair and make good the same as required by the Divisional Officer and the materials so brought to replace the said materials so repaired and made good shall also be considered as security for the said amount.

(5) 'Hurt the said materials shall not on any account be removed from the site of the said works except with the written permission of the Divisional Officer or an officer authorized by him in that behalf

(6) That the said amount shall be payable in full when or before the Contractor receives payment, from the Employer of the price payable to him for the said works under the terms and provisions of the said agreement PROVIDED THAT if any intermediate payments are made to the contractor on account of work done then on the occasion of each such payment the Government will be at liberty to make a recovery from the Contractors Bill for such payment by deducting there from in the value of the said materials (hen actually used in the construction and in respect of which recovery has not been made previously the value for this purpose being determined in respect of each description of material at (he rates at which the amount of the advances made under these presents were calculated.

(7) That if the Contractor shall at any time make any default in the performance or observation in any respect of any of the terms and provisions of the said agreement or of these presents the total amount of the advance or advances that may still be owing to the Employer shall immediately on the happening of such default be repayable by the Contractor to the Employer together with interest thereon at twelve percent per annum from the date or respective dates of such advance or advances to the date or repayment and with all costs, charges, damages and expenses incurred by the Employer in or for the recovery thereof or the enforcement of this security or otherwise by reason of (he default of the Contractor and any moneys so becoming due and payable shall constitute a debt due from the Contractor to the Employer and the Contractor hereby covenants and agrees with the Government to repay and the same respectively to it accordingly.

(8) That the Contractor hereby charges all the said materials with the repayment to the Employer of the said sum of Rupees - (Rs.....) and any further sum or sums which may be advanced as aforesaid and a ll costs charges damages and expenses payable under these present PROVIDED ALWAYS and it is hereby agreed and declared that not withstanding anything in the said agreement and without prejudice to the powers contained therein if and whether the covenant for payment and repayment hereinbefore contained shall become enforceable and the money owing shall not be paid to accordingly.

Once therewith the Employer may at any time thereafter adopt all or any of following courses as it may deem best :-

(a) Seize and utilize the said materials or any part thereof in the completion of the said works on behalf of the Contractor in accordance with the provisions in that behalf contained in the said agreement debiting the Contractor with the actual cost of effecting such completion the amount due in respect of advances under these presents and crediting the Contractor with the value of work done as he had carried it out in accordance with the said agreement and at the rates thereby provided. If the balance is against the Contractor he is to pay the same to the Government on demand.

(b) Remove and sell by public auction the seized materials or any part thereof and out of the moneys arising from the sale retain all the sums aforesaid repayable to the Employer under these presents and pay over the surplus (if any) to the Contractor.

(c) Deduct all or any part of the moneys owing out of the security deposit or any sum due to the Contractor under the said agreement.

(9) That except as is expressly provided by the presents interest on the aid advance shall not be payable.

(10) That in the event of any conflict between the provisions of these presents and the said agreement the provisions of these presents shall prevail and in the event of any dispute or difference arising over the construction or effect of these presents the settlement of which has not been hereinbefore expressly provided for the same shall be referred to the registrar IBA Karachi whose decision shall be final and the provisions of the Indian Arbitration Act for the time being in force so far as they are applicable shall apply to any such reference.

In witnesses whereof the* ---- - — — on behalf of the Employer IBA and the said — - --have hereunto set their respective hands and seals the day and first above written.

Signed, sealed and delivered by* In the presence of

Seal
1st witness 2nd witness

Signed, sealed and delivered by* In the presence of

Seal
1st Witness 2nd witness

FORM OF CONTRACT AGREEMENT

THIS CONTRACT AGREEMENT (hereinafter called the "Contract Agreement") made on the _____ day of _____ (month) 20____ between _____ (hereafter called the "Employer") of the one part an(hereafter called the "Contractor") of the other part.

WHEREAS the Employer is desirous that certain Works, viz _____ should be executed by the Contractor and has accepted a Bid by the Contractor for the execution and completion of such Works and the remedying of any defects therein.

NOW this Agreement witnessed as follows:

1. In this Agreement words and expressions shall have the same meanings as are respectively assigned to them in the Conditions of Contract hereinafter referred to.
2. The following documents after incorporating addenda, if any, except those parts relating to Instructions to Bidders shall be deemed to form and be read and construed as part of this Contract Agreement, viz:
 - (a) Letter of Acceptance;
 - (b) Specifications and Employer Design
 - (c) Contract Data;
 - (d) Conditions of Contract;
 - (e) Letters Technical Bid and Price Bid; (f) The priced Bill of Quantities; and (g) The Appendices to Bid.
3. In the event of any discrepancy or inconsistency within the Contract Documents, then the documents shall prevail in the order listed above.
4. In consideration of the payments to be made by the Employer to the Contractor as hereinafter mentioned, the Contractor hereby covenants with the Employer to execute and complete the Works and remedy defects therein in conformity and in all respects with the provisions of this Contract Agreement.
5. The Employer hereby covenants to pay the Contractor, in consideration of the execution and completion of the Works as per provisions of this Contract Agreement, the Contract Price or such other sum as may become payable under the provisions of this Contract Agreement at the times and in the manner prescribed therein.

IN WITNESS WHEREOF the parties hereto have caused this Contract Agreement to be executed on the day, month and year first before written in accordance with their respective laws.

Signature of the Contactor

Signature of Employer

(Seal)

(Seal)

In the presence of:

LIST OF APPROVED MANUFACTURERS (FIRE SUPPRESSION SYSTEM WORKS)

| Equipment / Material | Approved Manufacturers | Country of Origin |
|---|-------------------------------|--------------------------|
| Pressure Gauges | Viking | USA |
| | Tyco | USA |
| Gate Valves, Globe Valves, Strainers, Check Valves, Ball Valves, Butterfly Valves, OS & Y Valve, Shut Off Valve | KITZ | Japan |
| | Sffeco Nafco | UAE/Saudia Arabia |
| | Approved Equivalent | - |
| Supports & Anchors | Hilti | Germany/China |
| | Sikla | Germany |
| | Fischer | Germany |
| | Inka | Turkey |
| | Approved Equivalent | - |
| Concrete Fasteners | Rawl Plug Co. | UK |
| | Hilti | UK/Germany |
| | Fischer | Germany |
| | Inka | Turkey |
| Paint | Berger | Pakistan |
| | ICI | Pakistan |
| Fire Protection Piping and Fittings Black Steel, Schedule 40 Pipe | IIL | Pakistan |
| | MHS | Pakistan |
| | Protek | China |
| | Bristol | UAE |
| | SRI | Malaysia |
| Fire Hose Reels | Naffco | UAE |
| | Universal | Pakistan |
| | Bristol | UAE |
| | Rapid Drop | UK |
| Fire Hose Reels Cabinet & Door | Naffco | UAE |
| | Sffeco | UAE/Saudia Arabia |
| | Bristol | UAE |
| | Fighter | Pakistan |
| Fire Brigade Connection | Sffeco | UAE/Saudia Arabia |
| | Naffco | UAE |
| | SRI | Malaysia |
| Portable Fire Extinguisher | Naffco | UAE |
| | Sffeco | UAE/Saudia Arabia |
| | SRI | Malaysia |
| Fire Pumps | NM Fire pump | China |
| | EATON | Turkey |

| | | |
|-------------|-------|--------|
| | Nafco | UAE |
| Jockey Pump | NM | China |
| | Eaton | Turkey |
| | Nafco | UAE |

It is hereby certified that the terms and conditions have been read, agreed upon and signed.

M/s _____

Contact Person: _____

Address _____

Tel # _____ Fax # _____

Mobile # _____ CNIC # _____

E-mail: _____