

Institute of Business Administration (IBA)

Main Campus

Project : Fixing of Tiles & Making of Aluminum Window in NBP Office

Works : Repair & Miantenance Works in NBP Building

1. Item No.	2. Description of Item	3. Quantity	4. Unit
1	Cutting of Wall & Fixing of Aluminium Window (1'-6" x 7'-0")		
a	Cutting & dismantling of Block Masonry Wall in required shape at any level manually or mechanical using breaker, marking the exact location and cutting with grinder (outer periphery) including dispose off rubbish material from site. Also, making of window jambs by using cement sand mortar in (1:4) ratio, curing etc Supply and fix in position as specified anodized aluminum works as specified in Champagne colour of Chawla Aluminum with best quality glass of Ghani and all imported iron mongery & fillings, of Equivalent approved quality. This item includes mastic sealant to joints between the building openings and frames, complete in all respect as per drawings and specification. <u>Openable window with 5mm thick tinted glass.</u> <i>(Note: 3"x30 mm, section (1.2 mm thick), having item code No.7001 M, 70040 & 7008, shall be used)</i>	7	No's
2	Porcelain Tile (2' x 2')		
	Supply and lay homogenized full body porcelain tiles of required size & colours of prime quality of Shabbir, Master or equivalent as per approved sample, set with cement slurry/ Shabbir tiles or equivalent bond including filling and grouting the joints with grout and matching pigments, complete in all respect as per drawing and as directed by the Engineer. This item includes the remvoal of Plastic carpet on floor & chipping of the floor.		
a	On Floor:- With upto 12 mm thick setting bed in Shabbir or equivalent bond.	235	Sft
b	On Dado / Skirting :- with upto 12 mm thick setting bed in Shabbir or equivalent bond.	58	Rft
	Note: -As per attached BOQ. -Site Visit is mandatory before submission of quotation. -SST 13% will charge		

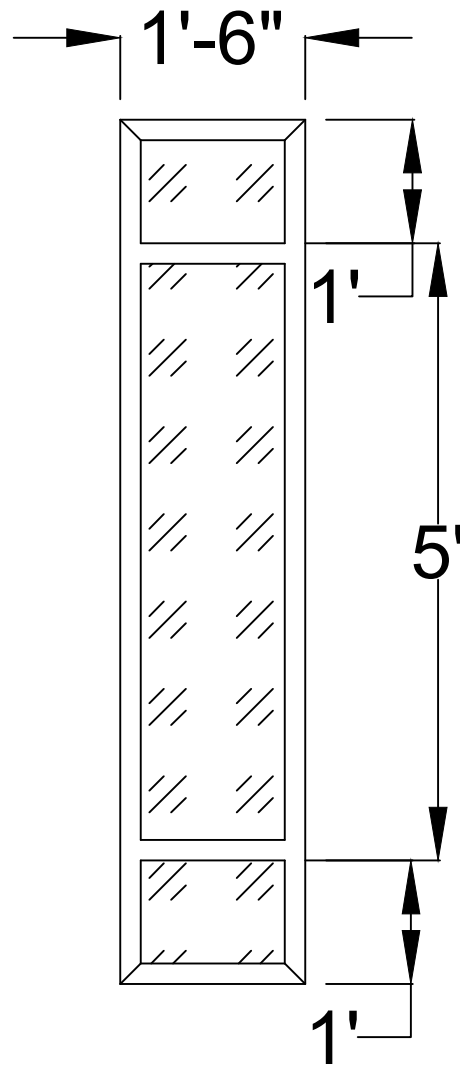

Aluminum Window Layout